

## 11 00 050 Removing and installing engine



**Working on 12 V vehicle electrical system.**

**Risk of short circuits! Risk of fire!**

- Make sure that **no charger** is connected to the jump start support point in the engine compartment.
- Detach battery earth lead from battery.
- With auxiliary batteries: Detach all battery earth leads from additional batteries.



**Motor vehicle may slip off the vehicle hoist where components are supported.**

**Danger! Life-threatening injuries!**

- Secure the vehicle hoist against lowering and lifting.



**Motor vehicle may slip off the vehicle hoist if the weight is distributed unevenly.**

**Danger! Life-threatening injuries!**

- Ensure there is a specific weight compensation on the motor vehicle.



**Vehicle may slip off the vehicle hoist if the vehicle hoist is handled incorrectly.**

**Danger! Life-threatening injuries!**

- Observe safety information on raising the vehicle using a vehicle hoist.
- For additional information see: 00 ... Raise the vehicle using a vehicle lift.



**Engine damage due to lack of engine oil.**

**Lack of engine oil after the cylinder head or the engine has been renewed may cause damage to the valve gear.**

- Do not start the engine after renewing the cylinder head or the engine without following the repair notes.
- The repair notes on renewing the cylinder head or the engine must be followed.
- For additional information, see: Repair notes on renewing the cylinder head or the engine

### PRELIMINARY WORK

---

**1 – Bring front compartment lid in the service position**

**Prerequisite**

Engine compartment lid is open.



### Shutting bonnet or tailgate.

#### Danger of injury!

- Support bonnet/tailgate in fully open position with the aid of a suitable device.

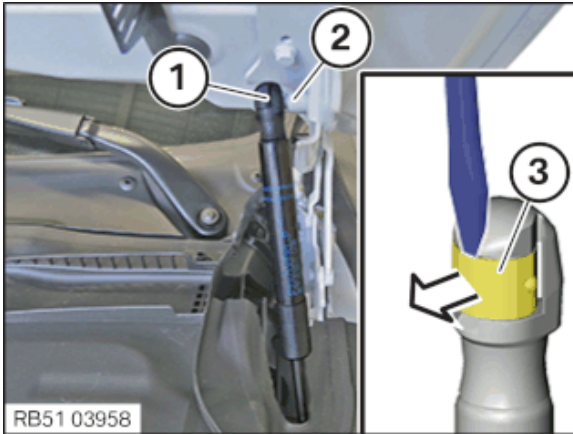

- Lift clamp (3) slightly using a screwdriver, in the direction of the arrow.
- Lift off ball socket (1) from ball pin (2).
- Repeat the operation on the other side of vehicle.

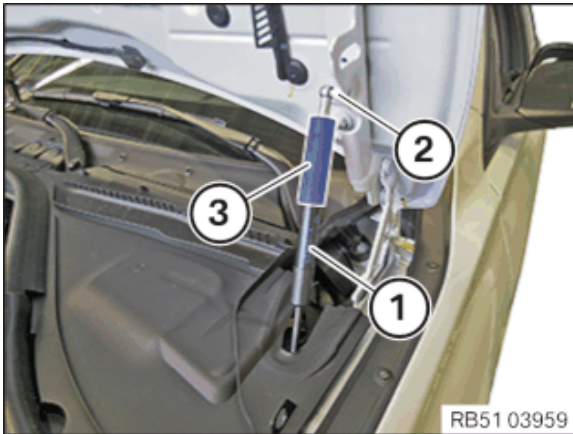

Conduct the following operation with the assistance of a second person.

- Remove the bonnet support and open the bonnet further.
- Push special tool **2 353 020** (3) over gas pressure spring (1).
- Place special tool on the ball pin (2) and engage using force.
- Repeat the operation on the other side of vehicle.

## 2 – Remove suspension cross-brace



Driving without the strut brace/front-end strut or tension strut is not permitted.

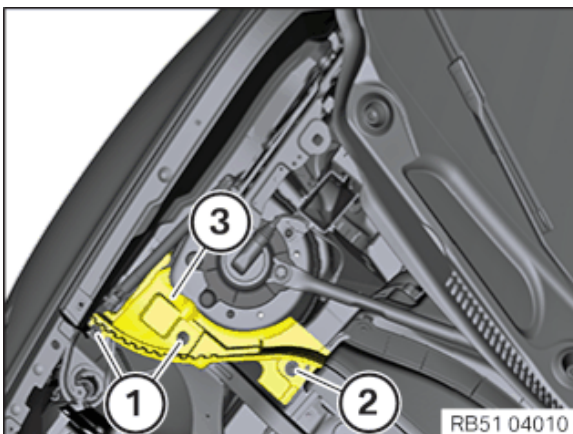

Description is for right component only. The procedure on the left side is identical.

- Loosen expanding rivet (1).
- Loosen screw (2).
- Remove the cover (3).

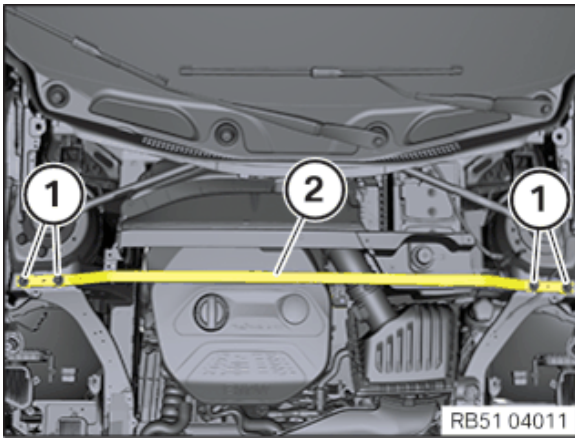

- Loosen screws (1).
- Remove strut brace (2).

### 3 – Remove the seal for the rear bonnet



Schematic diagram is for example purposes. Some parts may differ in certain details.

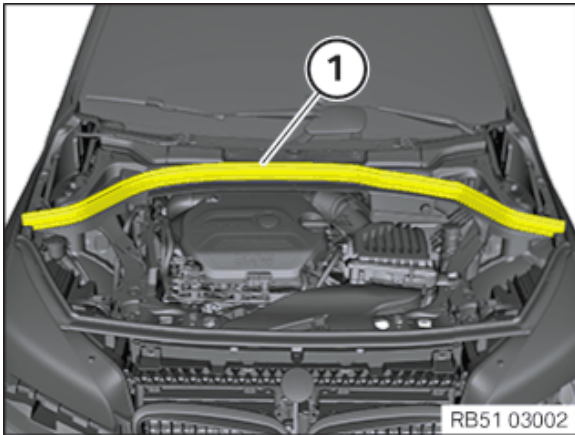

- Pull off the bonnet seal (1) towards the top and remove.

### 4 – Removing front cowl panel cover

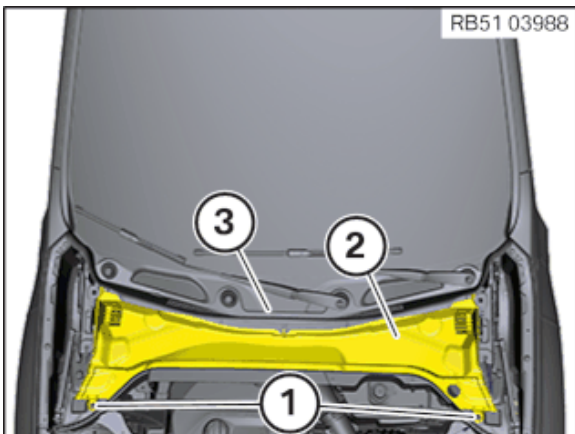

- Loosen the expanding rivet (1).
- Feed out and remove front cowl panel cover (2) from the rear cowl panel cover(3).

### 5 – Disconnecting the battery earth lead

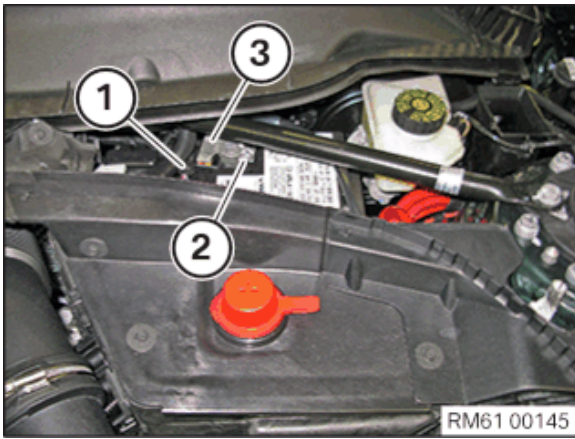

- Unlock plug connection (1) and disconnect.
- Unfasten nut (2).
- Remove the battery earth lead (3) and secure to one side.

## 6 – Removing the acoustic cover



**Hot surfaces.**

**Risk of burning!**

- Perform all work only on components that have cooled down.

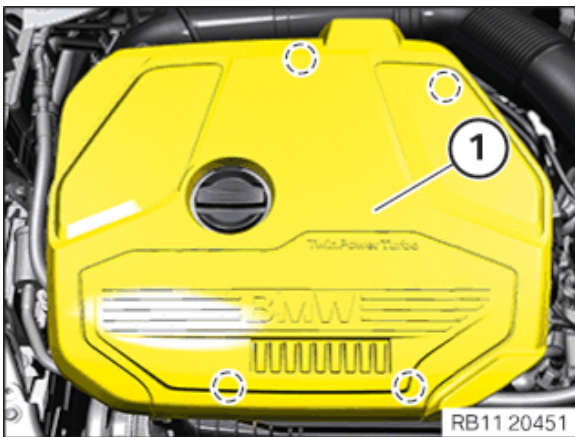

**Damage to the acoustic cover/design cover.**

**Jerky movements during disassembly and excessive application of force during installation may result in breakage of the acoustic cover/design cover.**

- Disassemble or mount the acoustic cover/design cover carefully.
- Disassemble or mount snap-lock couplings of the ball pivots one after the other.
- Disassemble or mount acoustic cover/design cover only at temperatures  $>20\text{ }^{\circ}\text{C}$ .
- Use only distilled water as an auxiliary material during installation, no lubricants.

- Unclip the acoustic cover (1) from the marked areas towards the top.

## 7 – Remove the intake neck for intake silencer housing

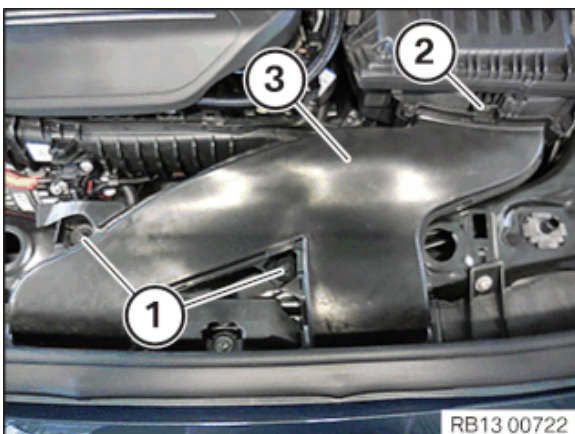

- Loosen nuts (1).
- Loosen the lock (2).
- Guide the intake neck (3) out and remove it.

## 8 – Removing intake silencer housing

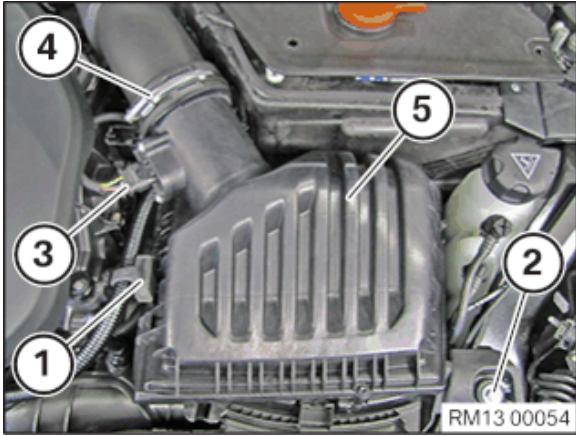

- Loosen the holder (1).
- Loosen screw (2).
- Unlock and release plug connection (3).
- Unfasten clamp (4).
- Pull out and remove the intake silencer housing (5) from the rubber mounts towards the top.

## 9 – Removing the upper bulkhead cover

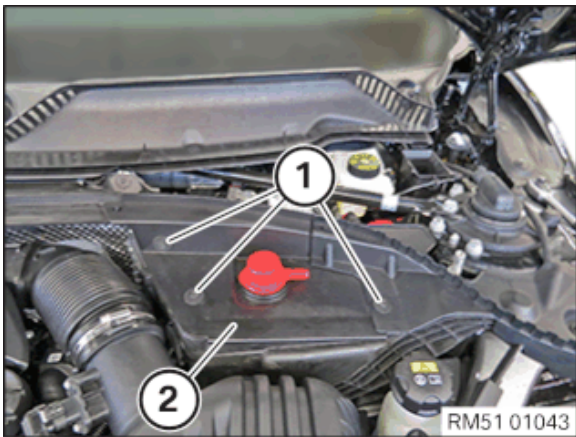

- Loosen screws (1).
- Guide out and remove the cover (2).

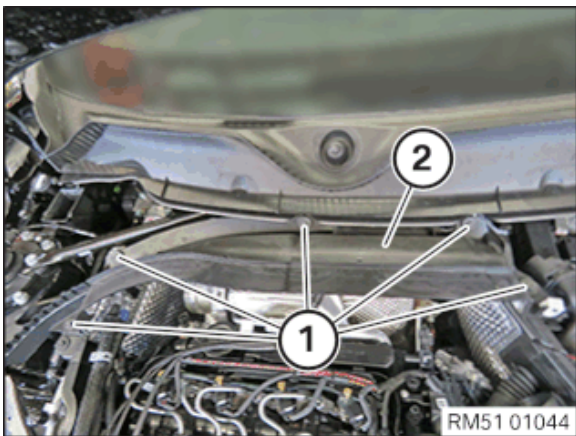

- Loosen screws (1).
- Feed out and remove the upper bulkhead cover (2).

## 10 – Removing system battery



**Working on 12 V vehicle electrical system.**

**Risk of short circuits! Risk of fire!**

- Make sure that **no charger** is connected to the jump start support point in the engine compartment.
- Detach battery earth lead from battery.
- With auxiliary batteries: Detach all battery earth leads from additional batteries.

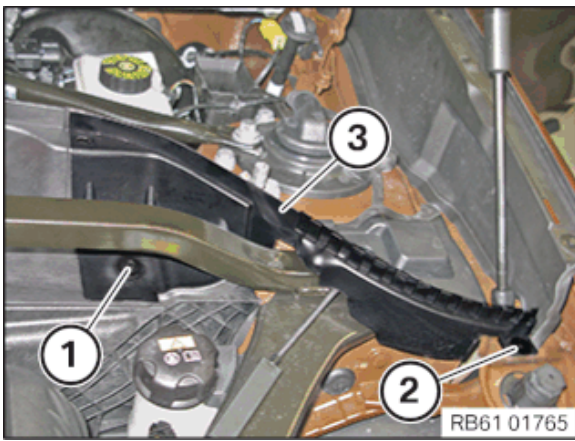

- Release the screw (1) and the expanding rivet (2).
- Remove the fixture for the gasket (3).

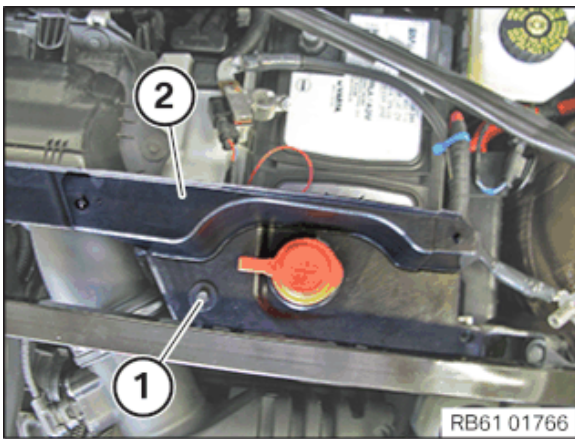

- Loosen screw (1).
- Remove the cover (2).

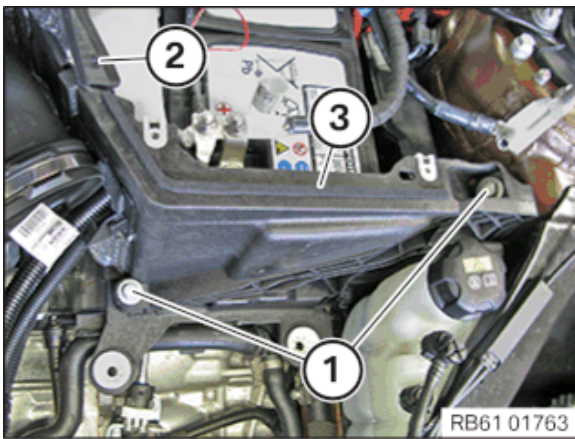

- Loosen screws (1).
- Unscrew the bolt (2) and guide the tension strut (3) out.

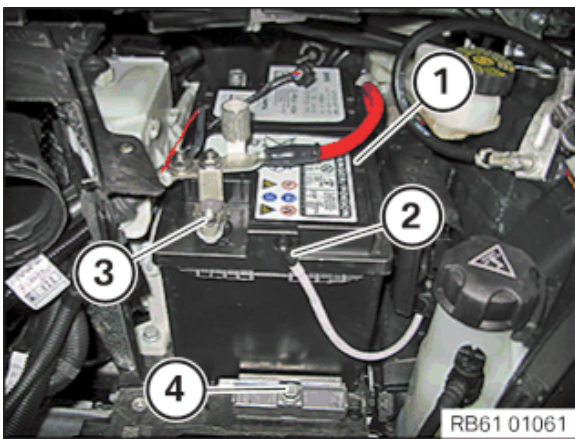

- Pull off the vent hose (2).
- Slacken the nut (3) on the positive battery terminal and remove the positive battery terminal.



**Unprotected battery terminals.**

**Risk of short circuits! Risk of fire!**

- Cover the vehicle battery.

- Loosen the screw (4) and remove the holder.
- Remove the system battery (1).

## 11 – Removing the DME control unit

### Prerequisite

Disconnect battery.



### **Electrostatic discharge.**

#### **Damage to or destruction of electrical components.**

- Leave electrical components in original packaging until just before they are installed. Use the original packaging only for any return shipments. Always package removed components straight away.
- Read and comply with user information on using the associated special tool 12 7 060.
- Only touch the housings of electrical components. Do not touch pins or multi-pin connectors directly.
- Wear electrically conductive clothing and antistatic shoes (with ESD symbol).
- For additional information see: 61 35 ... Notes for ESD protection (electrostatic discharge)



#### **Damage to wires when disconnecting connectors and plug connections.**

##### **Sheared wires can cause a short circuit.**

- Do not pull on the wires when disconnecting connectors and plug connections.



Follow instructions for removing and installing control units.

For additional information see: 12 00 ... Notes on removal and installation of control units



In a warranty case, you must always provide a fault memory printout with the defective part, even if the fault memory does not contain an entry.



Control unit must be programmed after it is replaced.

For additional information see: 61 00 ... Programming/encoding control unit(s)



Disconnecting control units may cause fault code entries and functional limitations. Fault code entries must be read out and deleted if necessary.

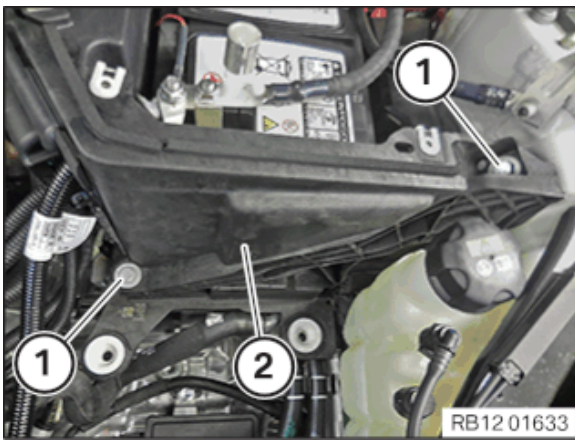

- Loosen screws (1).
- Guide out the tension strut (2) toward the top and remove it.

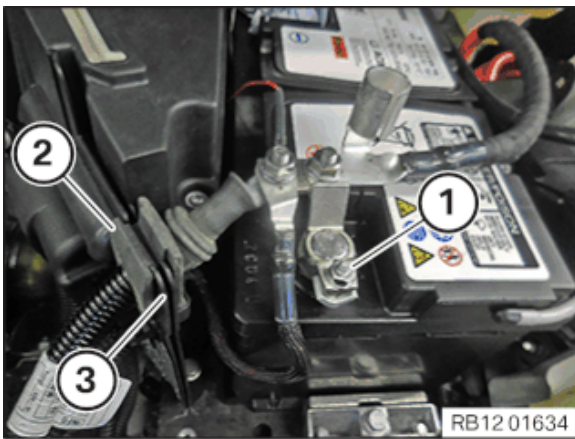

- Undo positive battery terminal (1).
- Feed out positive battery terminal (1) and set aside.
- Guide the positive battery cable (2) out of the holder (3) and lay to one side.

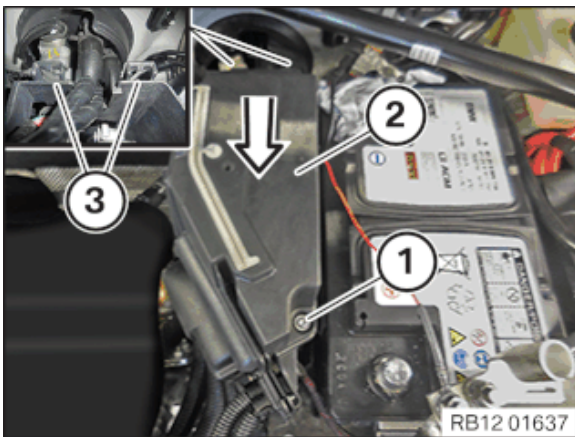

- Loosen screw (1).
- Unlock cover (2) and feed out and remove from the guides (3) in the direction of arrow.

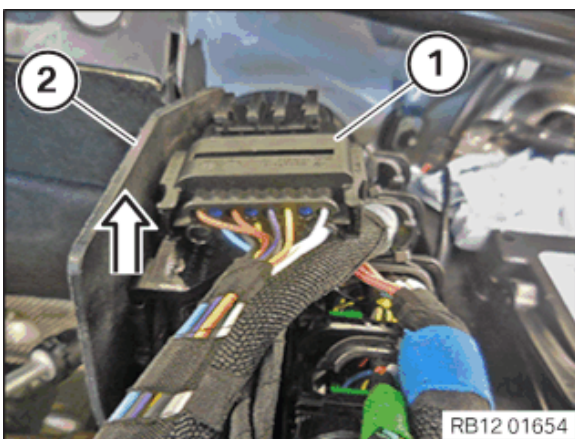

- Feed out connector (1) from the electronics box (2) and remove in the direction of arrow.
- Unlock and loosen connector (1).

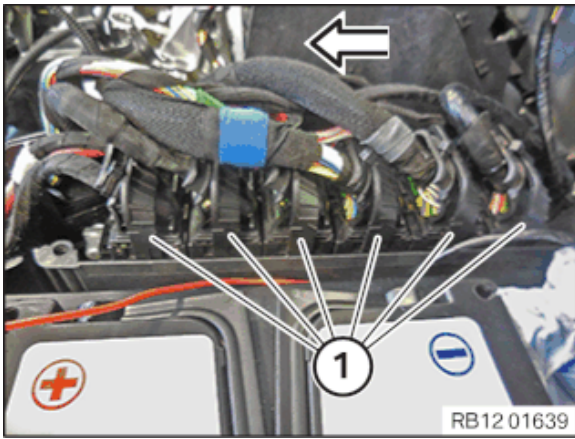

- Unlock and remove the connector (1) in the direction of the arrow.
- Feed out connector (1) and place to one side.

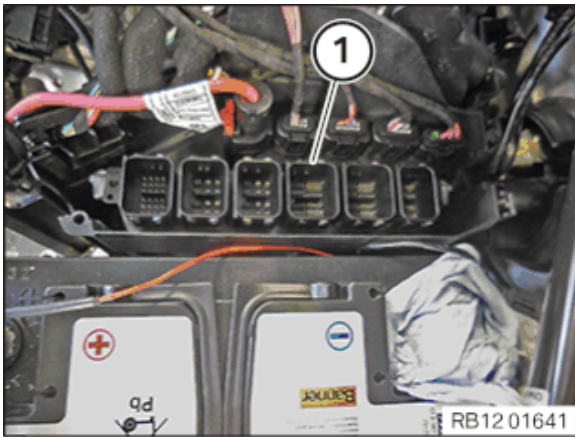

- Guide out the DME control unit (1) toward the top and remove.

## 12 – Removing integrated supply module (PDM)



### **Electrostatic discharge.**

#### **Damage to or destruction of electrical components.**

- Leave electrical components in original packaging until just before they are installed. Use the original packaging only for any return shipments. Always package removed components straight away.
- Read and comply with user information on using the associated special tool 12 7 060.
- Only touch the housings of electrical components. Do not touch pins or multi-pin connectors directly.
- Wear electrically conductive clothing and antistatic shoes (with ESD symbol).
- For additional information see: 61 35 ... Notes for ESD protection (electrostatic discharge)



#### **Damage to wires when disconnecting connectors and plug connections.**

##### **Sheared wires can cause a short circuit.**

- Do not pull on the wires when disconnecting connectors and plug connections.

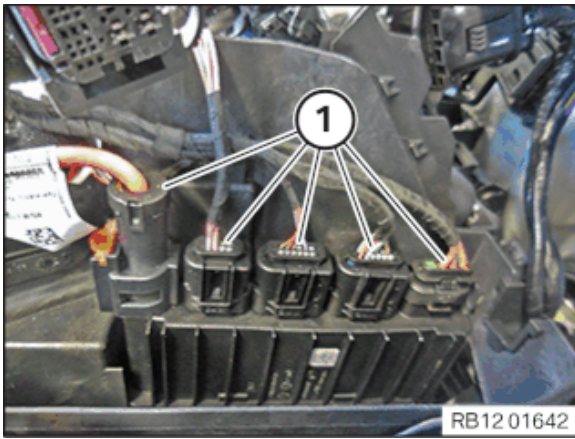

- Unlock and disconnect the plug connection (1).

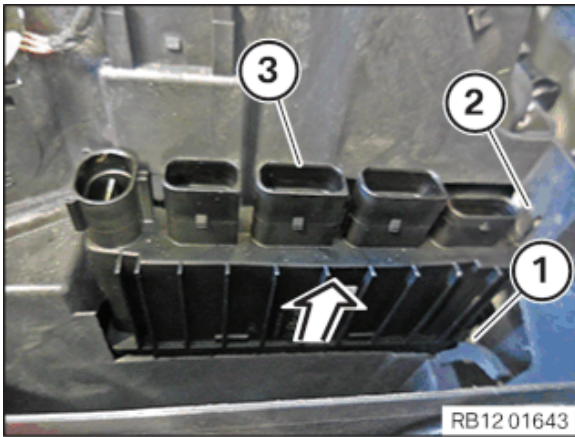

- Disengage locks (1) and (2).
- Guide out and remove the integrated supply module (3) in the direction of the arrow.

### 13 – Remove electronics box

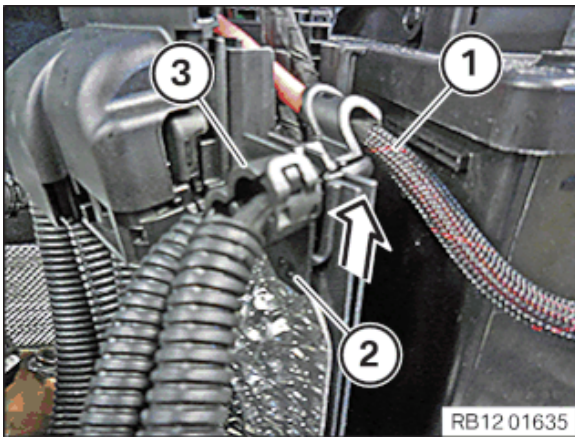

- Thread out positive battery cable (1) and set it aside.
- Unlock lock (2).
- Guide out the wiring harness section (3) for the injectors and ignition coils in direction of arrow and set it aside.

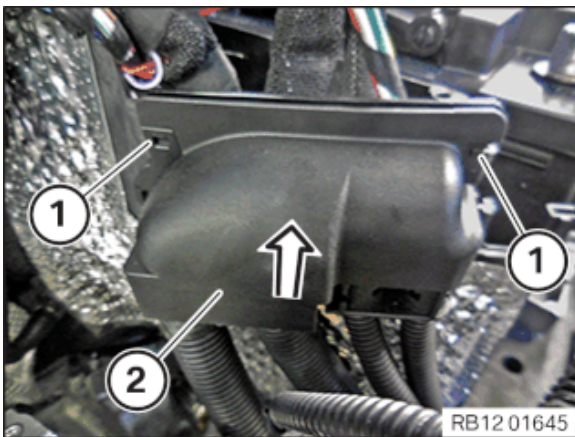

- Unlock the locks (1).
- Guide out the wiring harness section (2) for the Valvetronic servomotor in direction of arrow and set it aside.

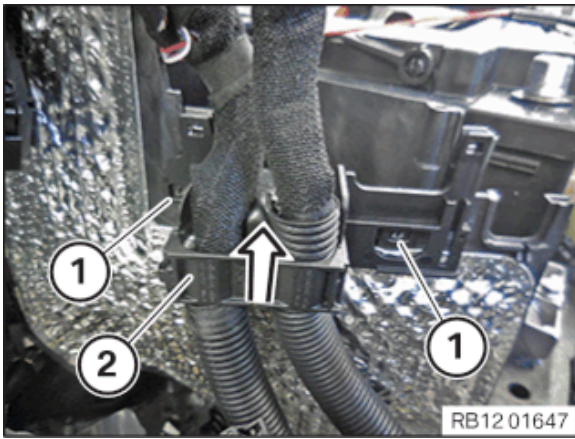

- Unlock the locks (1).
- Feed out wiring harness section (2) of the engine in direction of arrow and set it aside.

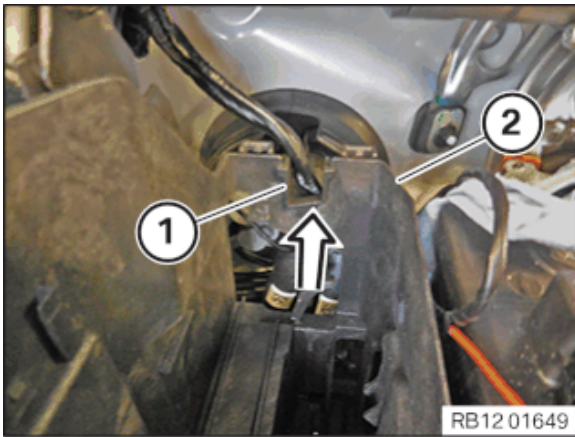

- Unlock the holder (1) and feed it out of the electronics box (2) in direction of arrow and set it aside.

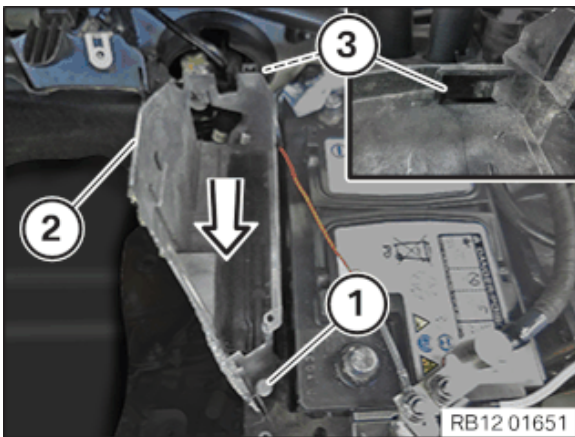

- Loosen screw (1).
- Guide the electronics box (2) out of the guide (3) in direction of arrow and remove.

#### 14 – Removing the oil filler cap

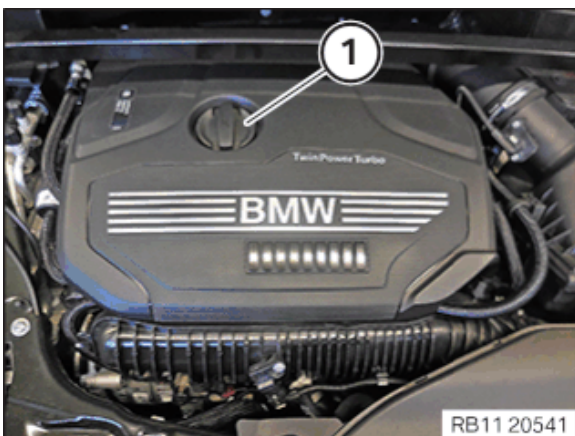

- Open oil filler cap (1).

#### 15 – Remove cross connection

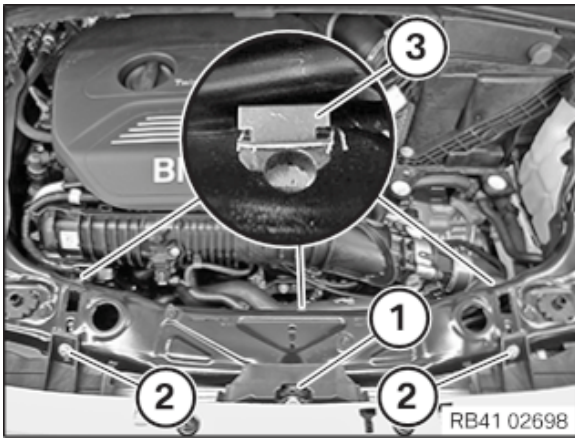

- Loosen screws (1) and (2).
- Detach clamps (3) for bonnet lock Bowden cable.

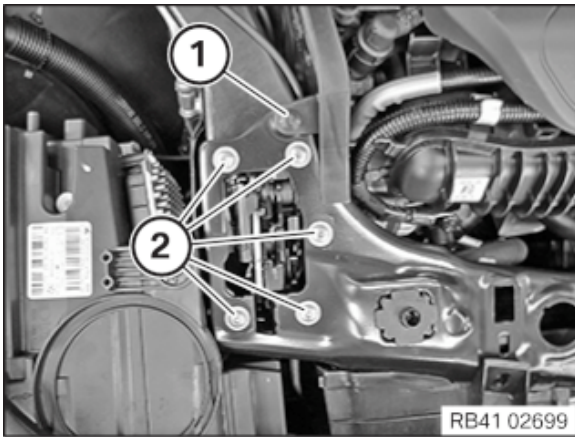

- Lever out expanding rivet (1).
- Loosen screws (2).

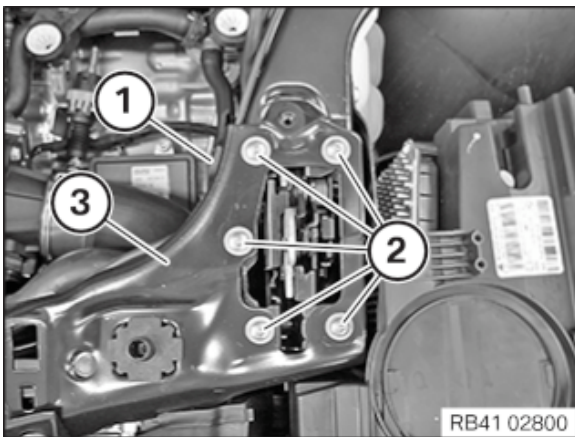

- Lever out expanding rivet (1).
- Loosen the screws (2) and remove the cross connection (3).

## 16 – Removing the fan cowl with electric fan



**Hot surfaces.**

**Risk of burning!**

- Perform all work only on components that have cooled down.

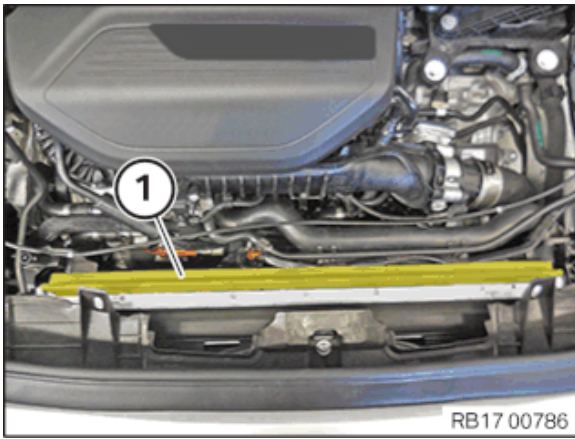

- Feed out and remove the sealing (1) from the radiator.

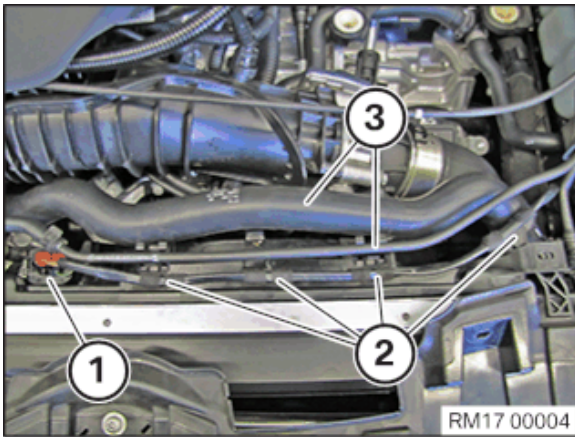

- Unlock plug connection (1) and disconnect.
- Unlock and loosen the clamps (2).
- Feed out connector (1) and place to one side.
- Feed out coolant lines (3) and lay to one side.

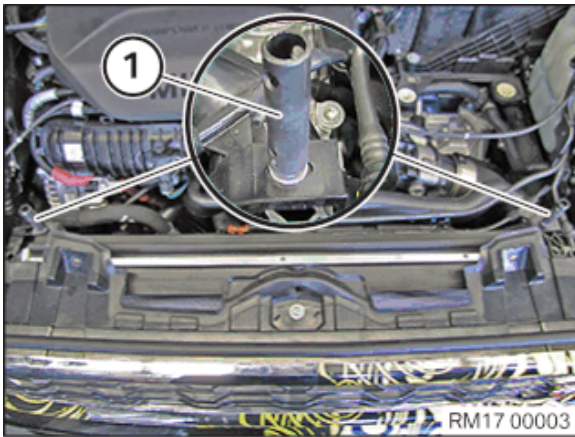

- Loosen screws (1).

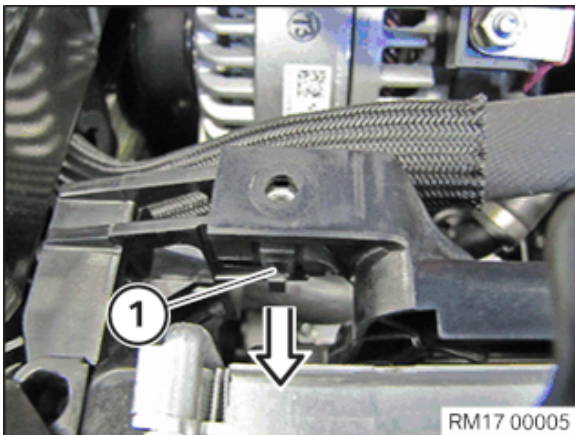

- Unlock the right lock (1) on the fan cowl in the direction of the arrow.

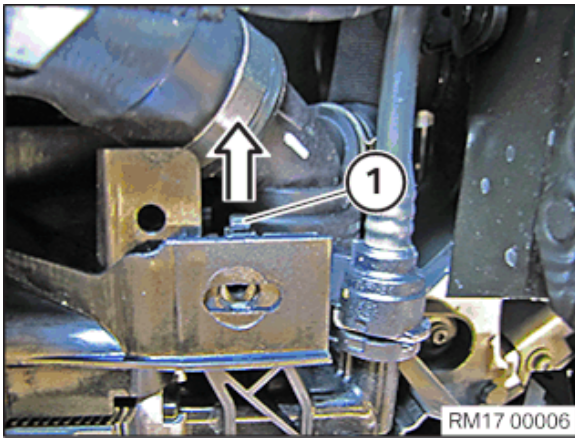

- Unlock the left lock (1) on the fan cowl in the direction of the arrow.

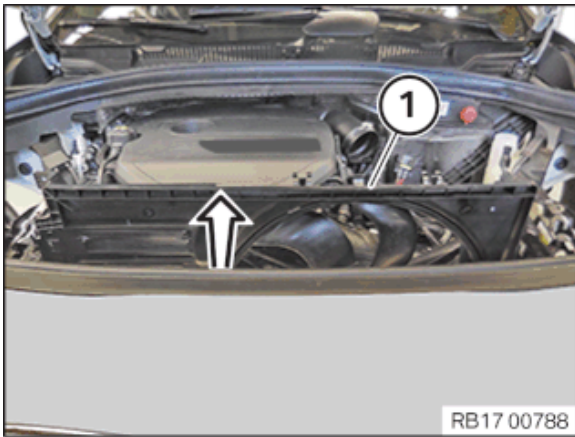

- Feed out fan cowl (1) with electric fan in direction of arrow and remove.

## 17 – Remove the front left and right wheel



Perform the operations on the left and right side.



### ► Removing the wheel

- If several wheels are removed simultaneously: Use a piece of chalk to mark on each tyre the axle and side on which the corresponding wheel is fitted.
- Unscrew the wheel bolts (arrows) and remove the wheel.

Use the matching adapter from tool set (wheel bolt adapter set) to loosen and tighten down the wheel bolt with security code.

## 18 – Removing the front right wheel arch cover

### ► Remove the front wheel arch trim



To provide a better overview: Schematic diagram with partially hidden components.



Description is for left component only. Procedure on the right side is identical.

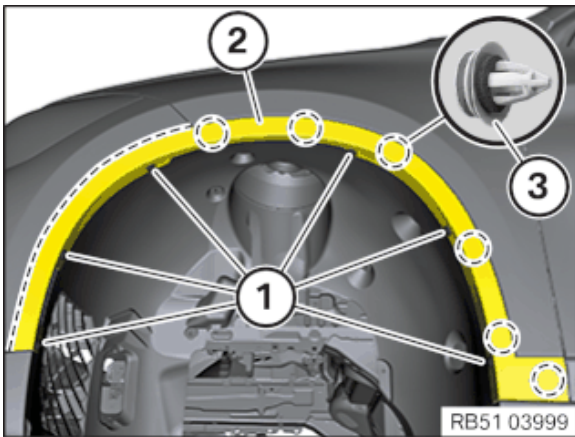

- Remove the blind rivets (1).
- Release the wheel arch trim (2) in the area of the side panel from the clips (3).
- Release the wheel arch trim (2) from the latch mechanisms on the bumper and remove.

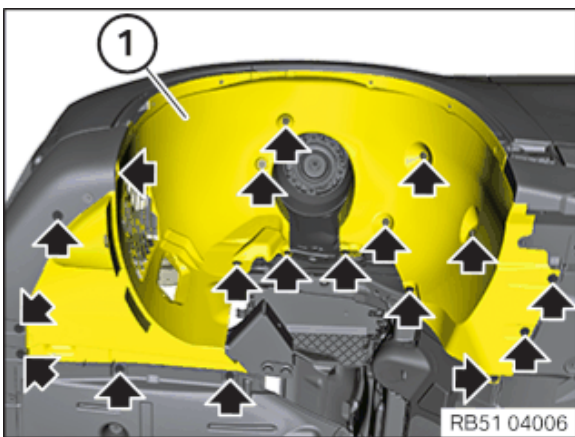

Description is for left component only. Procedure on the right side is identical.

- Unscrew all bolts and nuts (arrows).
- Guide the wheel arch cover (1) out.

## 19 – Removing the front underbody protection

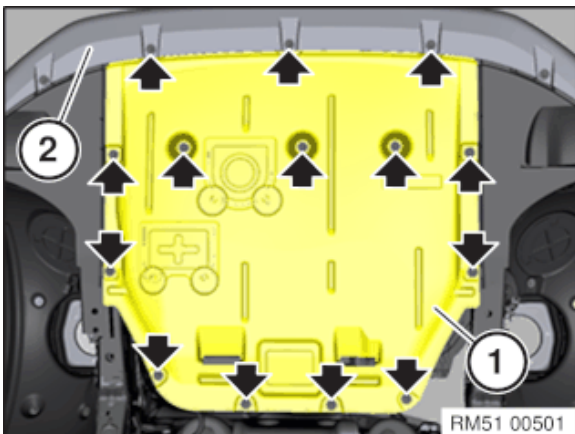

- Remove screws (arrows).
- Pull out and remove front underbody protection (1) under the bumper panel (2).

## 20 – Remove pressure pipe between exhaust turbocharger and charge air cooler



**Hot surfaces.**

**Risk of burning!**

- Perform all work only on components that have cooled down.

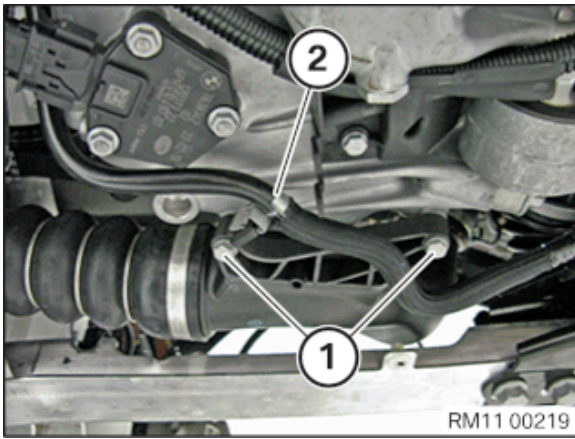

- Loosen screws (1).
- Guide the line (2) out and set it aside.

RM11 00219

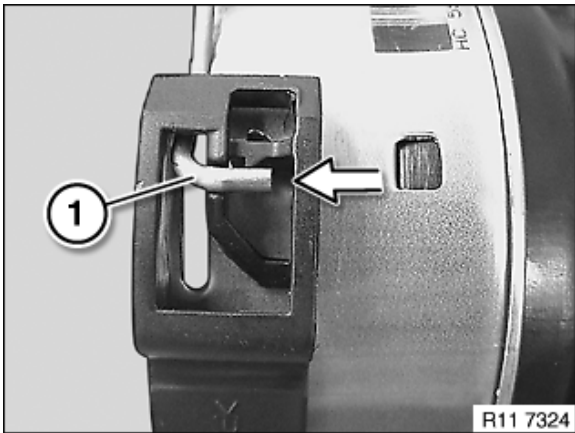

- Unlock the lock (1).  
The lock (1) must engage in the bracket during unlocking (arrow).

R11 7324

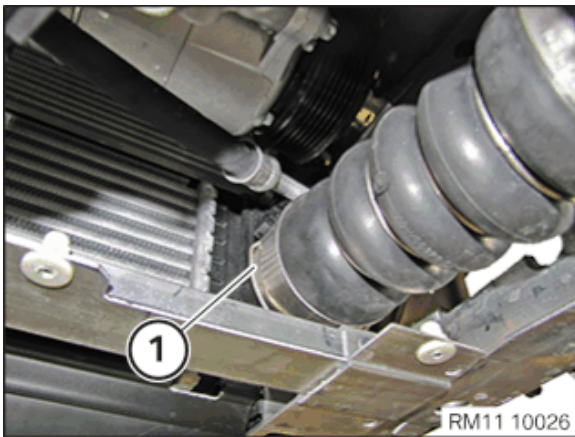

- Unlock and loosen the pressure pipe (1) on the charge air cooler .

RM11 10026

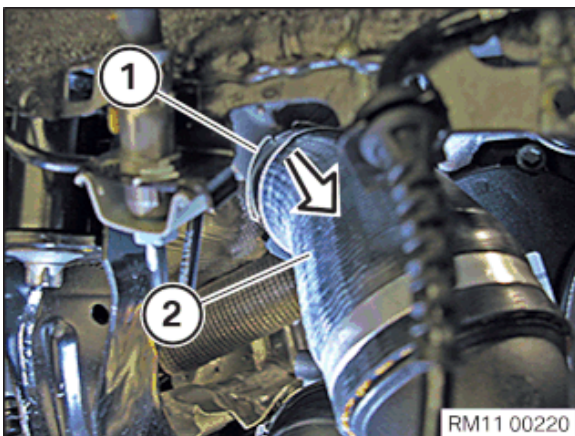

- Unlock and detach the locks (1) on both sides.
- Guide out the pressure pipe (2) at the exhaust turbocharger in the direction of the arrow and set it aside.

RM11 00220

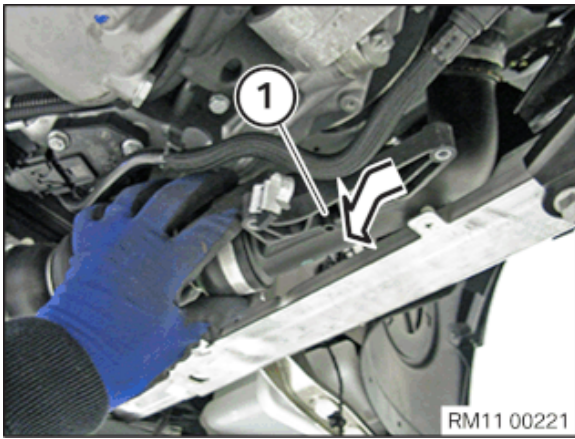

- Remove the pressure pipe (1) in the direction of the arrow.

## 21 – Remove the pressure pipe between the throttle body and the charge air cooler



**Hot surfaces.**

**Risk of burning!**

- Perform all work only on components that have cooled down.

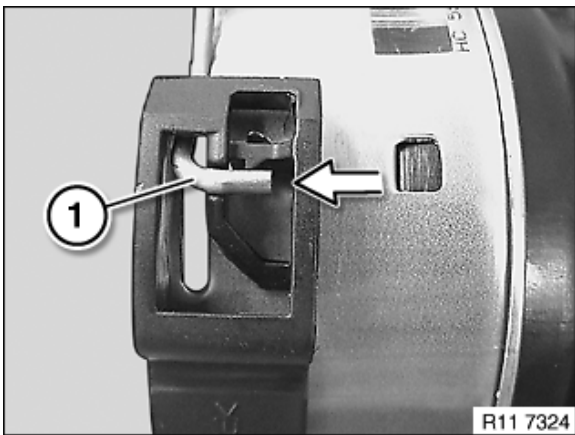

- Unlock lock (1).  
The lock (1) must engage in the bracket (arrow).

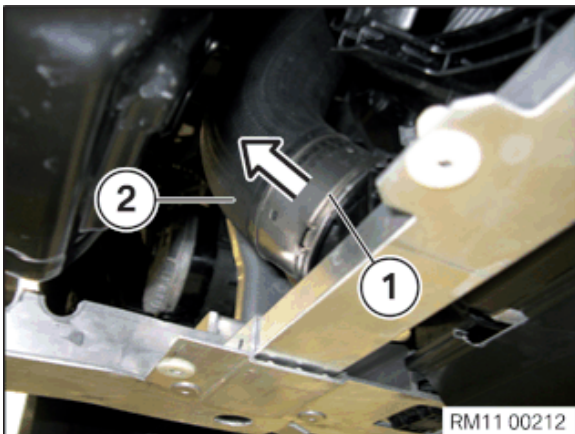

- Unlock and detach the locks (1) on both sides.
- Guide out the pressure pipe (2) in the direction of the arrow and set it aside.

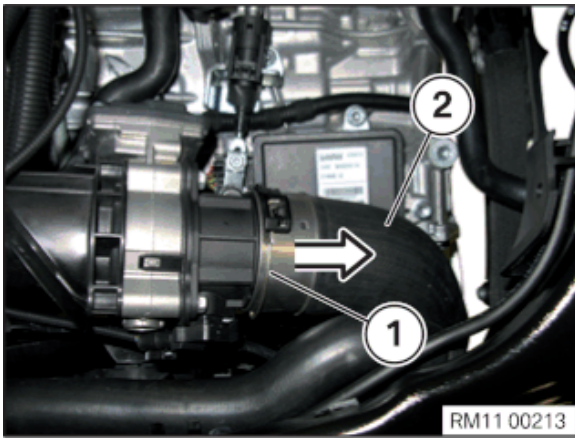

- Unlock and detach the locks (1) on both sides.
- Guide out the pressure pipe (2) in the direction of the arrow and set it aside.

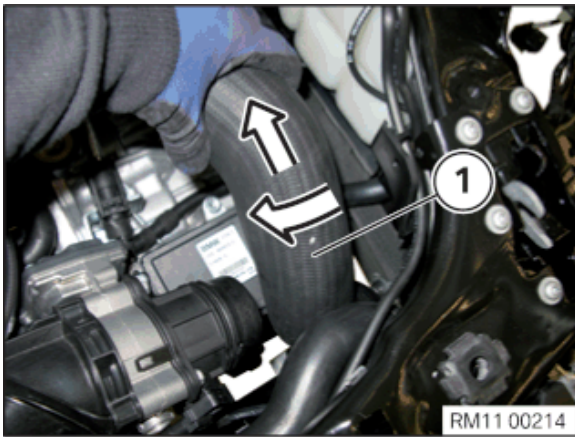

- Remove the pressure pipe (1) in the direction of the arrow.

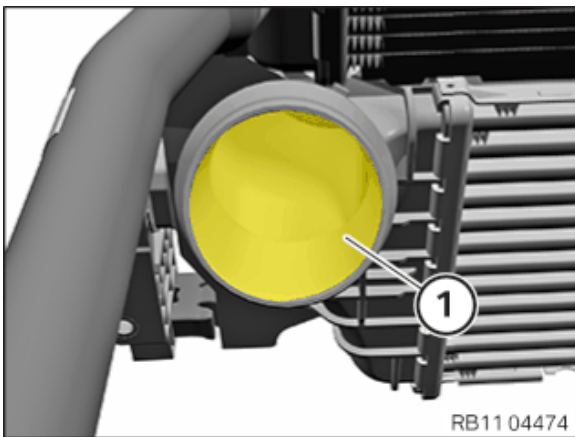

Schematic diagram is for example purposes. Some parts may differ in certain details.

- Lock the opening (1) of the charge air cooler with a suitable auxiliary material.

## 22 – Releasing the oil drain plug



**Hot fluids.**

**Risk of scalding!**

- Conduct all work in the vehicle wearing appropriate personal protective equipment only.



Collect and dispose of emerging fluids. Observe country-specific waste disposal regulations.

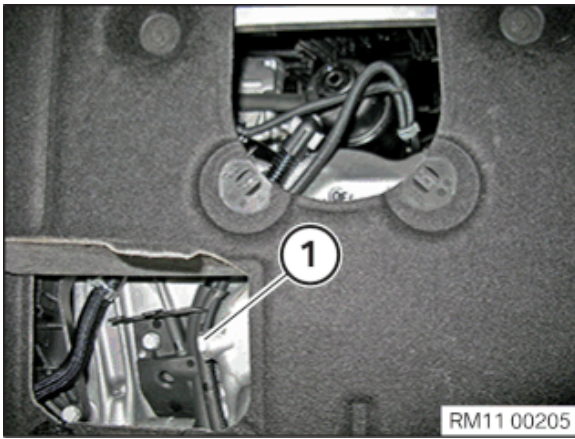

- Release oil drain plug (1).
- Allow the engine oil to drain out fully.

### 23 – Tightening the oil drain plug

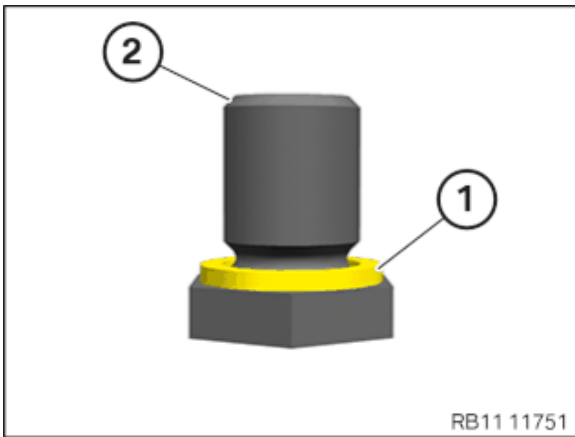

- Renew sealing ring (1) on the oil drain plug (2).
- Parts:** Sealing ring
- Guide in the sealing ring (1) on the oil drain plug (2) and install.

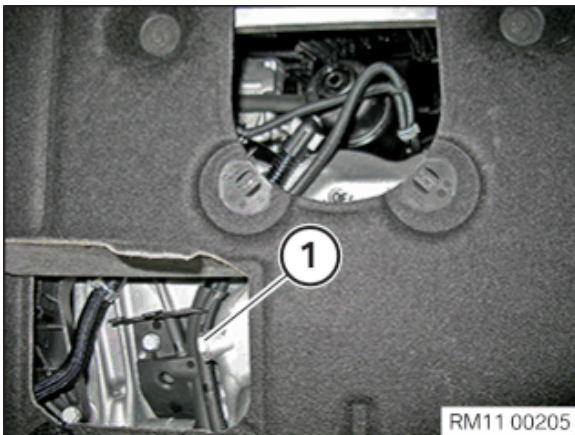

- Guide in oil drain plug (1) and install.
- Tighten oil drain plug (1).

#### Oil drain plug on oil sump

M12x1.5	Renew the sealing ring.	Tightening torque	25 Nm
---------	-------------------------	-------------------	-------

### 24 – Draining the oil level in the manual gearbox (GS6-58BG, GS6-59DG)



**Materials harmful to health.**

**Contact with fluids harmful to health!**

- Note and follow safety information on containers.
- Conduct all work in appropriate personal protective equipment only.

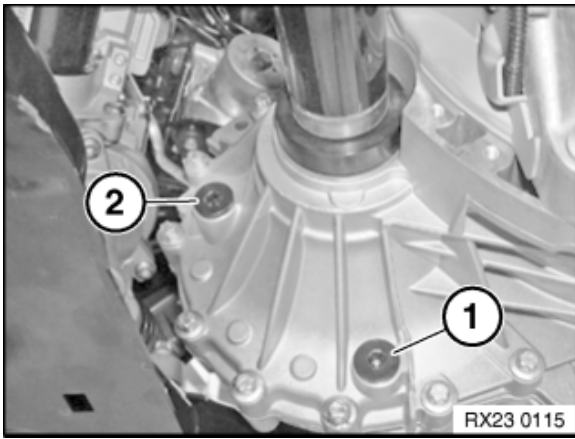

- Draining transmission oil:
  - Release oil drain plug (1) and oil filler plug (2).
  - Clean oil drain plug (1) and screw in.

**Oil drain plug / oil filler plug**

Tightening torque	43 Nm
-------------------	-------

**25 – Drain the coolant from the coolant circuit**



**Hot fluids.**

**Risk of scalding!**

- Conduct all work in the vehicle wearing appropriate personal protective equipment only.



**Life-long fill of coolant!**

Do not reuse used coolant.

When replacing and removing components which rely on the corrosion protection effect of the coolant, it is essential to change the coolant. The cooling system must therefore be emptied and refilled.

In the case of other removal work involving the draining of part quantities of coolant, the coolant level must be topped up with new coolant.



Collect and dispose of emerging fluids. Observe country-specific waste disposal regulations.

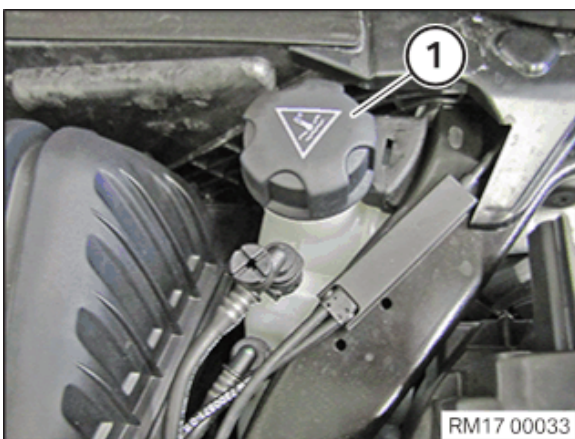

- Loosen sealing cap (1).

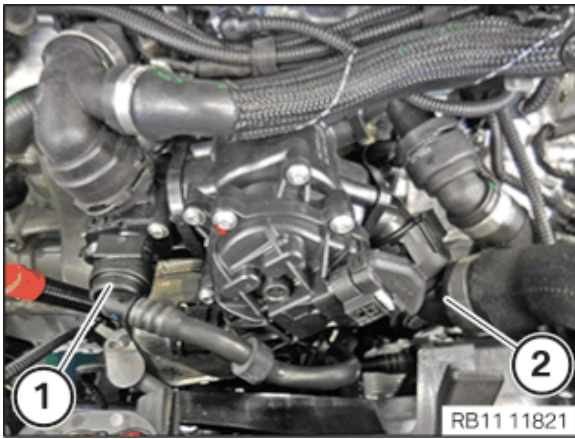

- Unlock and loosen coolant line (1).
- Unlock and loosen coolant line (2).
- Catch and dispose of escaping coolant.

## 26 – Connect the coolant line



Make sure that the connections are locked correctly. The locks must engage audibly.

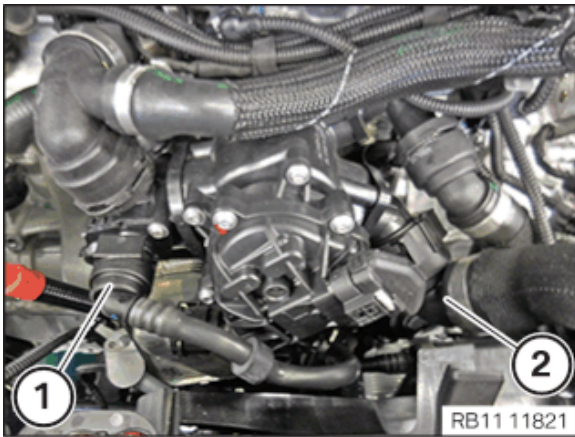

- Connect and lock coolant line (1).
- Make sure the coolant line (1) engages audibly.
- Connect and lock coolant line (2).
- Make sure that the cooling line (2) engages audibly.

## 27 – Install the locating pin

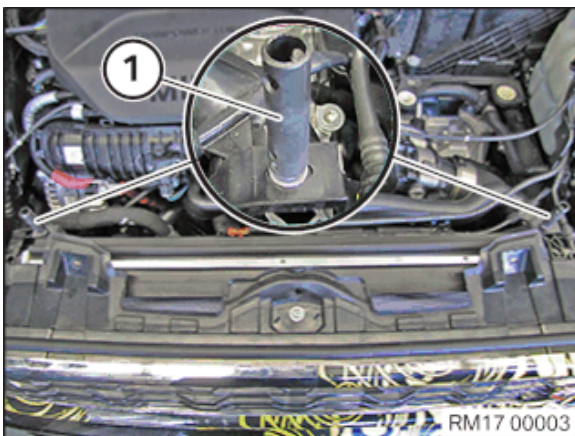

- Tighten the locating pin (1).

### Fan cowl on radiator

M6X12

Tightening  
torque

6 Nm

## 28 – Install cross connection

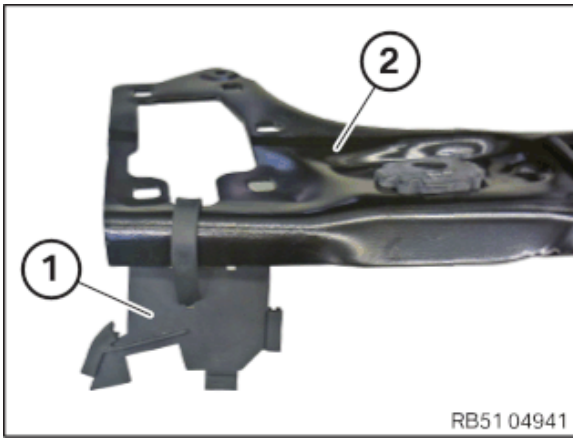

- Installed on the right side only on vehicles with production date as of: 12/2016
- Secure spray guard (1) to cross connection (2) as shown.

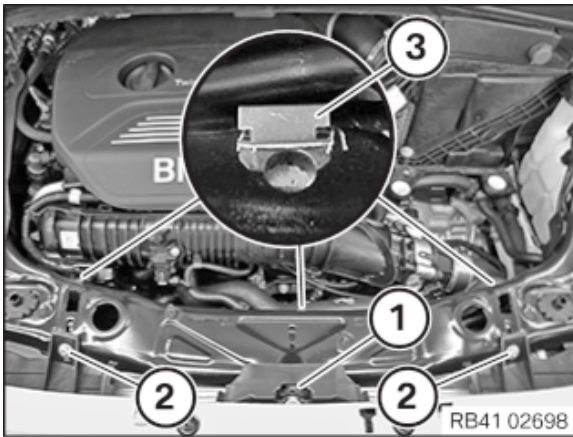

- Install cross connection.
- Position all screws.
- Tighten down screw (1).

#### Bracing strut to top cross connection

M8	Tightening torque	25 Nm
----	-------------------	-------

- Tighten the screws (2).

#### Air duct to deformation element/cross connection

M6x20 screw	Tightening torque	6 Nm
-------------	-------------------	------



#### Incorrect routing of the Bowden cable for the bonnet lock.

#### Abrasion of the coolant ventilation line, coolant loss and engine overheating.

- Route the Bowden cable of the bonnet lock correctly under the lock bridge.
- Hook the Bowden cable to all the clips.
- Make sure that the Bowden cable has no contact with the coolant ventilation line.

- Fasten clamps (3) for bonnet lock Bowden cable to cross connection.
- Tighten screws (2) of cross connection (3).

#### Cross connection on support for cross connection

M6x20	Tightening torque	12 Nm
-------	-------------------	-------

- Fasten expanding rivet (1).

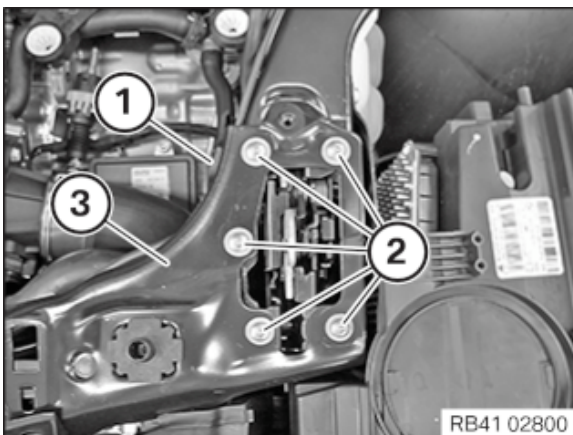

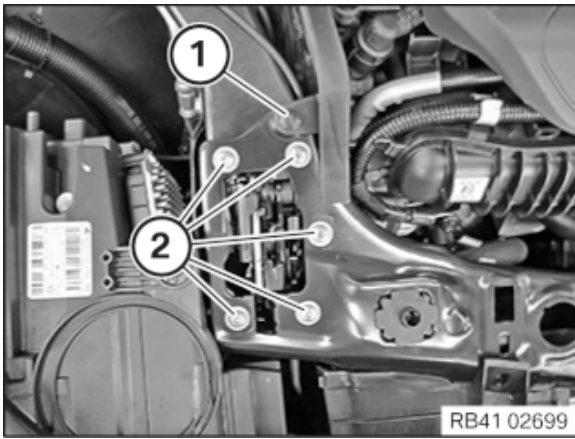

- Tighten the screws (2).

#### Cross connection on support for cross connection

M6x20	Tightening torque	12 Nm
-------	-------------------	-------

- Fasten expanding rivet (1).

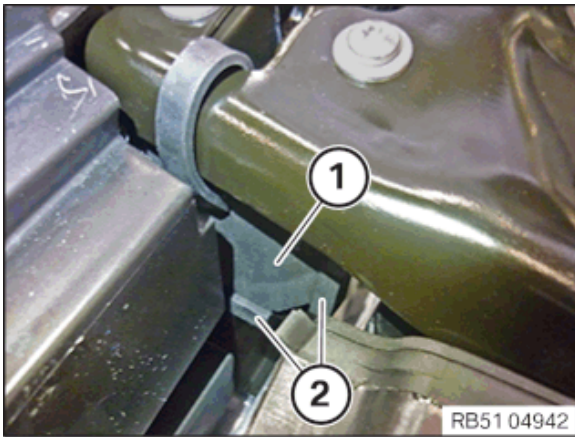

- **Installed on the right side only on vehicles with production date as of: 12/2016**

- Mount spray guard (1) correctly to prevent corrosion.
- Secure spray guard (1) to the lock bridge with retaining tabs (2).

### 29 – Fastening the coolant radiator on the left and right

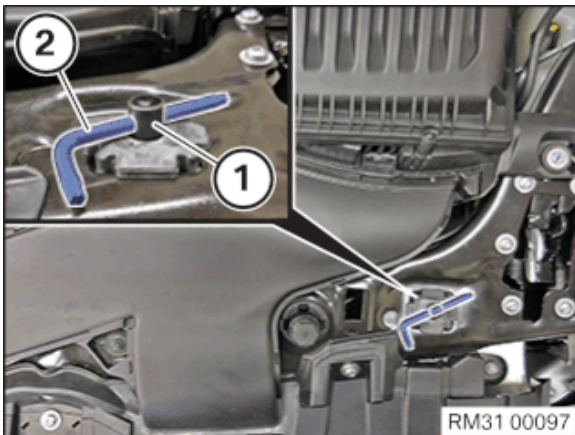

Perform the operations on the left and right side.

- Fasten the coolant radiator to centering pin (1) using a suitable tool (2).

### 30 – Removing starter motor



**Hot surfaces.**

**Risk of burning!**

- Perform all work only on components that have cooled down.



### Working on 12 V vehicle electrical system.

#### Risk of short circuits! Risk of fire!

- Make sure that **no charger** is connected to the jump start support point in the engine compartment.
- Detach battery earth lead from battery.
- With auxiliary batteries: Detach all battery earth leads from additional batteries.



### Electrostatic discharge.

#### Damage to or destruction of electrical components.

- Leave electrical components in original packaging until just before they are installed. Use the original packaging only for any return shipments. Always package removed components straight away.
- Read and comply with user information on using the associated special tool 12 7 060.
- Only touch the housings of electrical components. Do not touch pins or multi-pin connectors directly.
- Wear electrically conductive clothing and antistatic shoes (with ESD symbol).
- For additional information see: 61 35 ... Notes for ESD protection (electrostatic discharge)

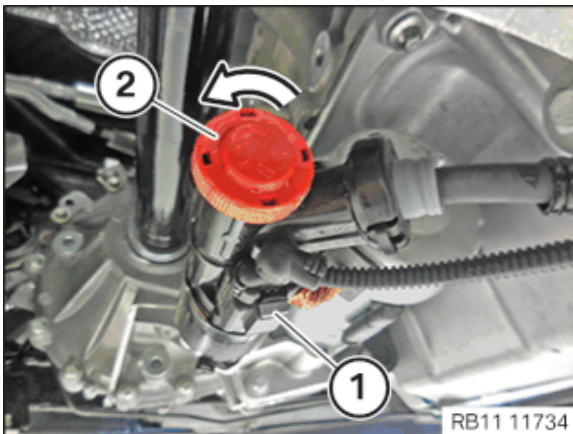

- Unlock and loosen connector (1).
- Detach the sealing cap (2) in the direction of the arrow.
- Feed out and remove the sealing cap (2).

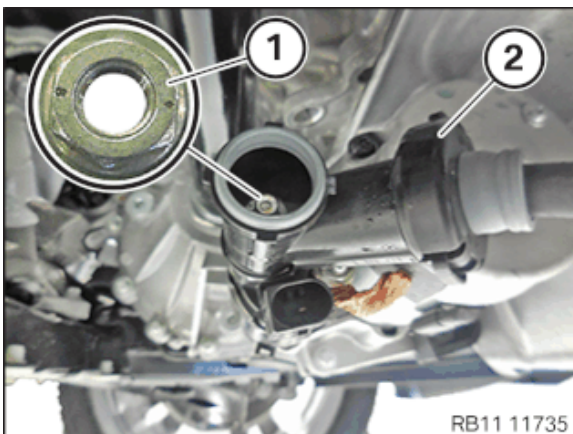

- Unfasten nut (1).
- Feed out the positive battery cable (2) of the starter motor and set it aside.

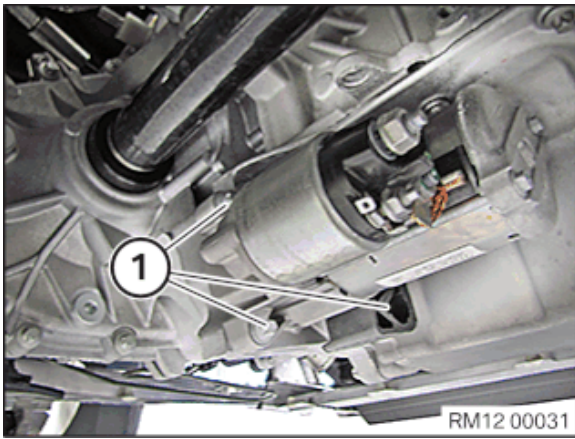

- Loosen screws (1).
- Feed out starter motor and remove.

### 31 – Releasing lower steering shaft from steering gear



#### Damage to steering column switch cluster (SZL).

The steering column switch cluster (SZL) or the coil spring cassette may be damaged by twisting of the steering wheel if the lower steering shaft (or the universal joint) is separated from the steering gear or from the steering column.

- After disconnecting the steering shaft (or the universal joint) from the steering gear or from the steering column, secure the steering wheel against twisting.

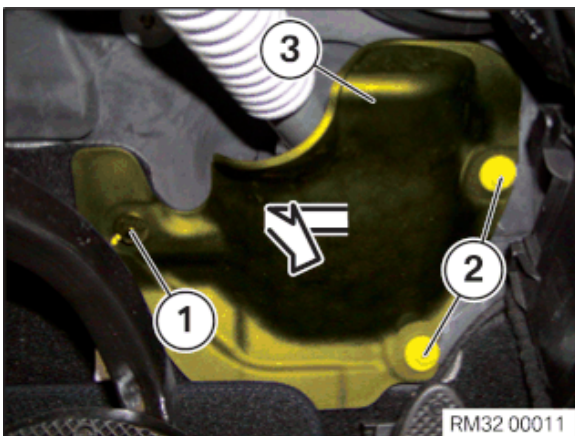

The following work step(s) is / are to be carried out if the specified component(s) is/are fitted.

- Loosen nut (1).
- Slacken the nuts (2).
- Feed out the cover (3) in the direction of arrow and remove it.

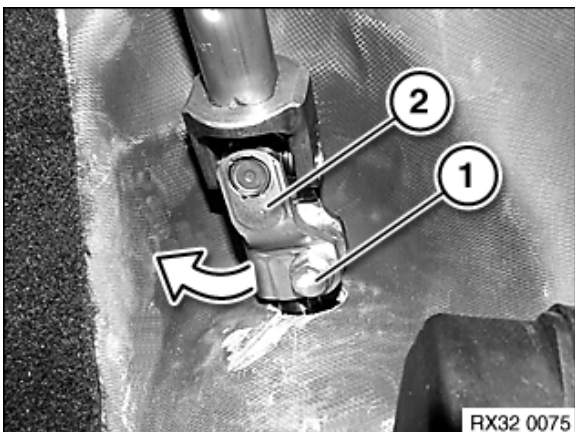

- Loosen screw (1).
- Release the universal joint (2) of the steering shaft at bottom in the direction of arrow from the steering gear and swivel it to the side.

### 32 – Disconnecting plug connections from steering gear

- If installed: Detach connectors from the front axle carrier

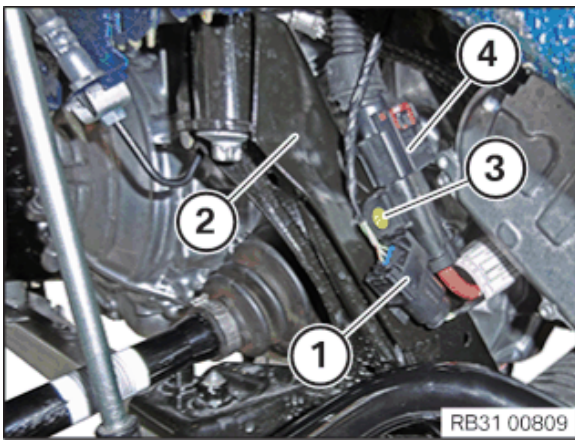

- Release the plug connection (1) from the front axle support (2).
- Loosen screw (3).
- Release the plug connection (4) from the front axle support (2).

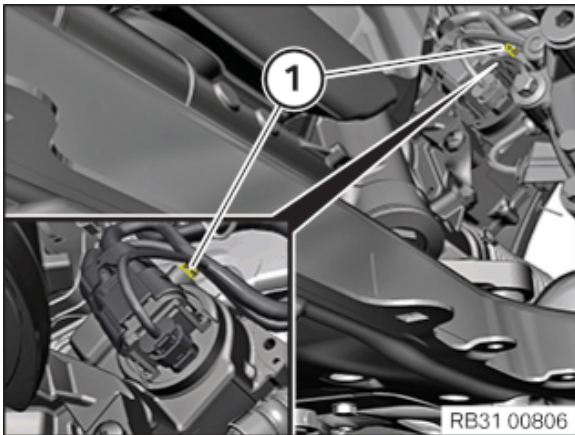

- Disconnect wiring harness (1) from steering gear.

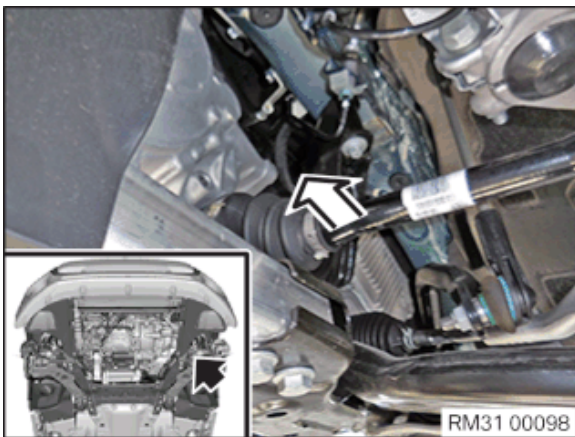

- To unlock the plug connections (see the following work step): unlock plug connections (arrow) with the right hand.  
The plug connections can be reached via the left-hand output shaft.

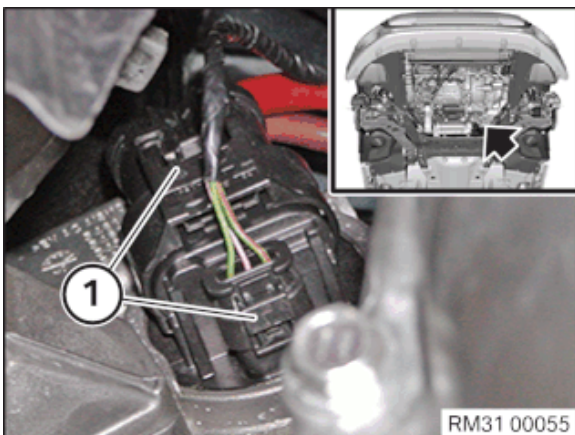

- Unlock plug connections (arrow) (1) and disconnect from the steering gear.
- Make sure when lowering the front axle that the cables are not damaged!

### 33 – Disconnecting purge air line

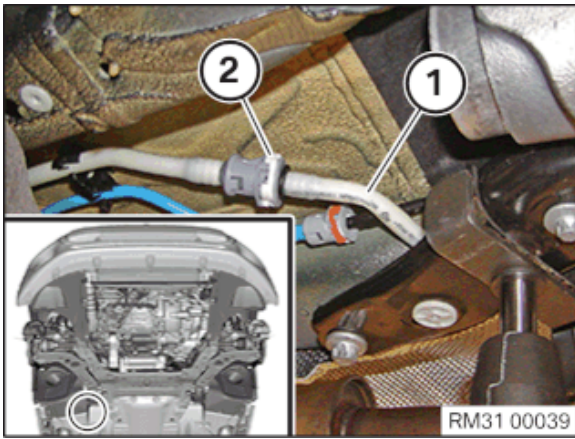

- Unlock lock (2).
- Disconnect purge air line (1).

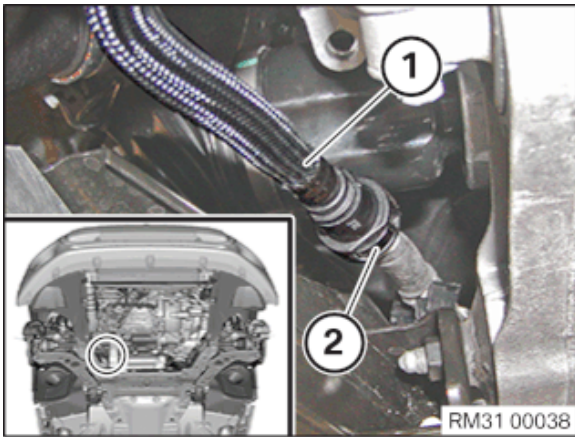

- Unlock lock (2).
- Disconnect purge air line (1).

### 34 – Releasing the left and right anti-roll bar from the anti-roll bar link



Perform the operations on the left and right side.

#### ► Releasing the anti-roll bar from the anti-roll bar link

- Loosen nut (1).
- Note:** Use the Torx socket for counter support.
- Loosen the anti-roll bar link from the anti-roll bar .

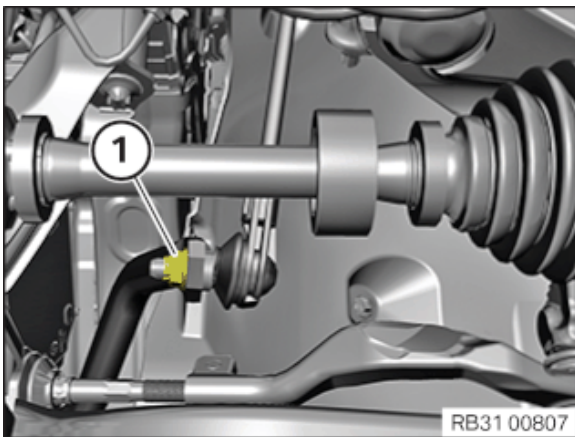

### 35 – Releasing the mounted part from the front axle support

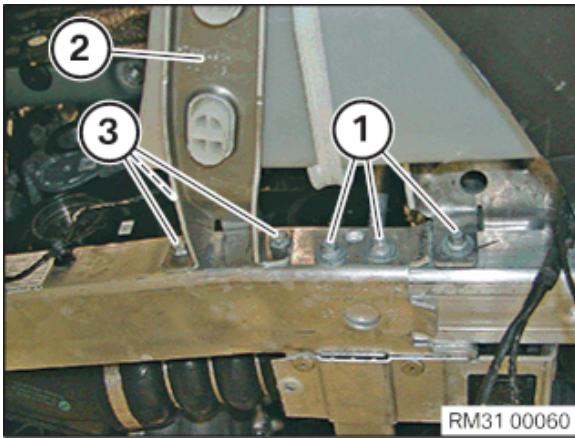

- **Only on right side:** Loosen screws (3) and remove holder for washer fluid reservoir (2).



Perform the operations on the left and right side.

- Loosen screws (1).

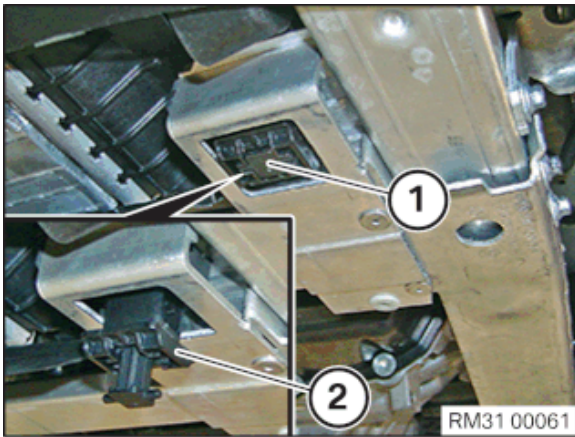

Perform the operations on the left and right side.

- Unlock safety catch (1) of the lock (2) from the holder for the charge air cooler.
- Completely remove locks (2).

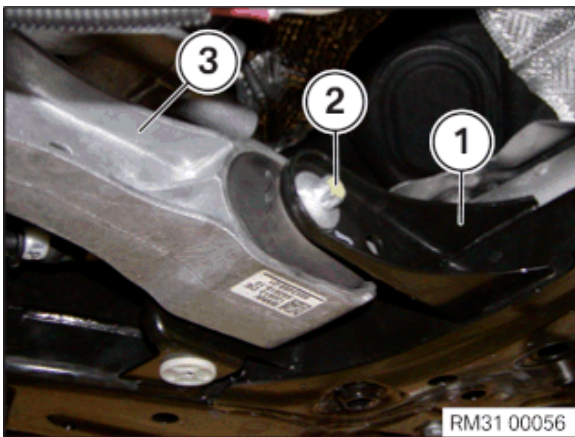

- Loosen screw (2) of the engine support (3) on the front axle (1).



Perform the operations on the left and right side.

- Loosen screws (1).

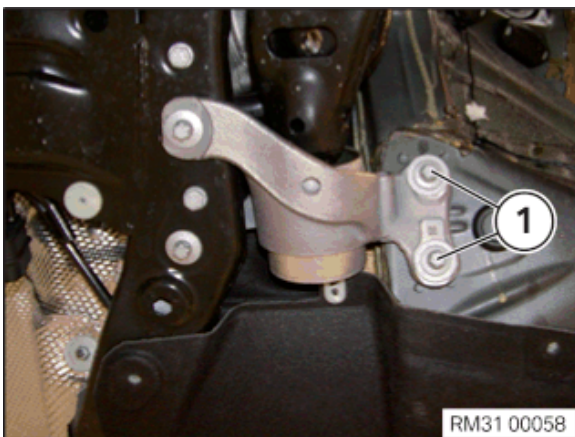

### 36 – With right installation: Detaching ride height sensor cable

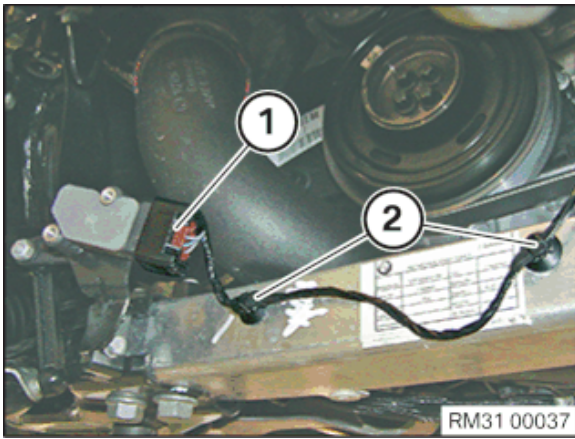

- Unlock plug connection (1) and disconnect.
- Release cable clip (2) from deformation element adapter.

### 37 – Detaching rubber mount from front axle support

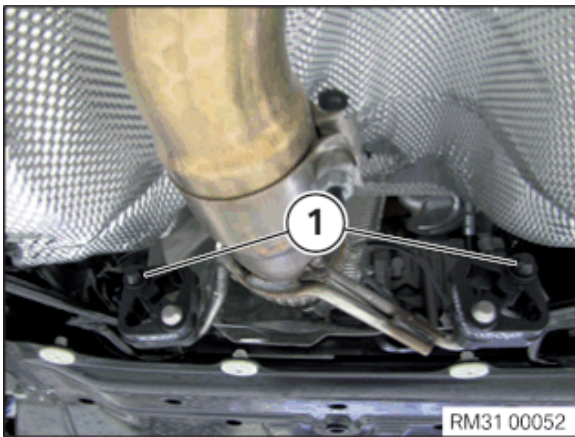

- Spray rubber mount (1) with lubricant and release from holder on front axle support.

### 38 – Detaching and removing front axle completely

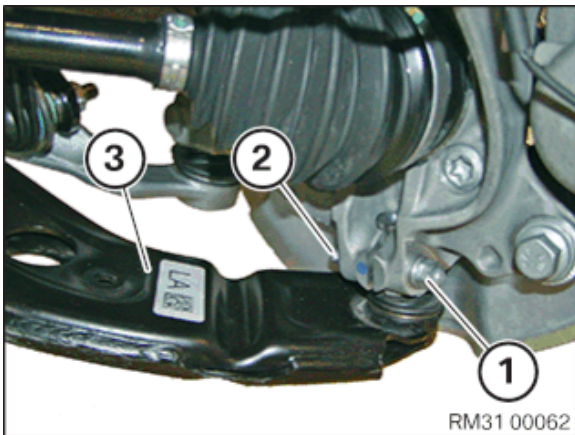

Perform the operations on the left and right side.

- Loosen nut (1).
- Pull out screw (2).
- Detach the wishbone (3) from the swivel bearing .

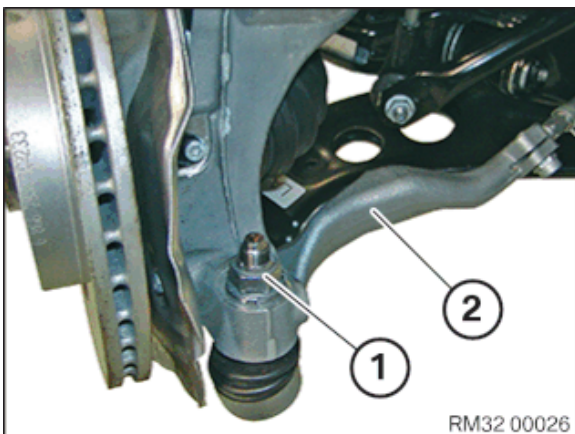

Perform the operations on the left and right side.

- Loosen nut (1).
- Detach the track rod (2) from the swivel bearing.

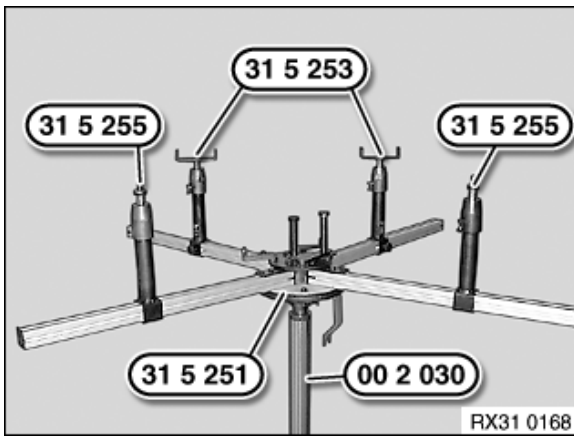

- With the help of an auxiliary person, connect the special tool **0 495 817 (31 5 251)** completely to the universal jack **0 490 133 (00 2 030)**.
- Insert the special tools **0 495 821 (31 5 255)** into the telescopic supports of a profile rail pair.
- Insert the special tools **0 495 819 (31 5 253)** into the telescopic supports of other profile rail pair.

**Note:** In a profile rail pair, two profile rails are connected to one another by gearing.

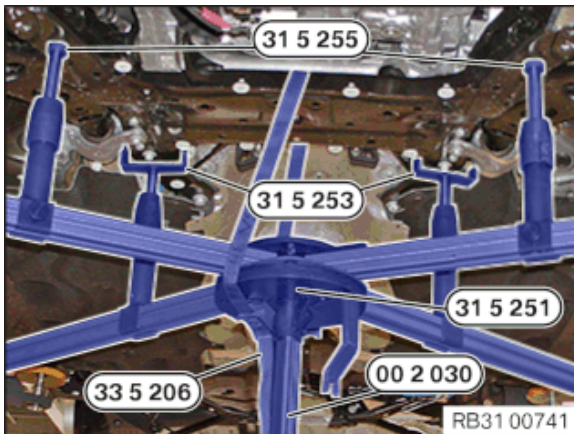

- Align the special tools **0 495 821 (31 5 255)** and **0 495 819 (31 5 253)** with the front axle support.
- Support the front axle support by operating the universal jack **0 490 133 (00 2 030)**.

**Note:** The centre of gravity of the front axle support must be positioned centrally over the workshop jack!

- Secure the front axle support with special tool **0 496 080 (33 5 206)** to the special tool **0 495 817 (31 5 251)**.

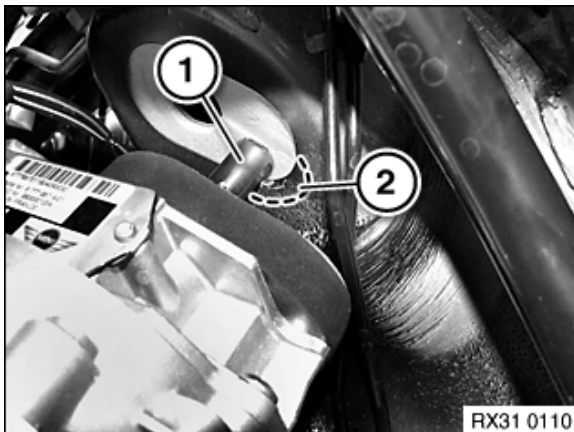

**Failure to comply with the specifications.**

**Component damage.**

- All specifications for installation and removal **must** be observed.
  - When lowering and raising the front axle support, make sure that the torsion bar (1) of the electromechanical steering gear (EPS) in the area (2) does not collide with the bulkhead!
- Note:** Collision with the bulkhead may result in damage to the electromechanical steering gear (EPS)!

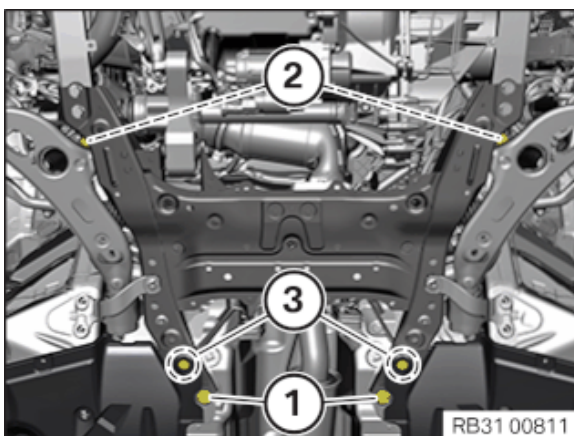

- If necessary, release the screws in the areas (3).
- Release screws (1) (front axle support, rear).
- Release screws (2) (front axle support, front).
- Bend the underbody panellings in the areas (3) to one side.
- Release the charge air cooler from the rubber mounts when lowering.
- Completely lower and the front axle remove.



Note the information on thread repairs using Helicoil thread inserts.

For more information see: 41 00 ... Notes on repairing threads

- Check thread for damage; if necessary, repair with Helicoil thread insert.

### 39 – Removing right output shaft partially

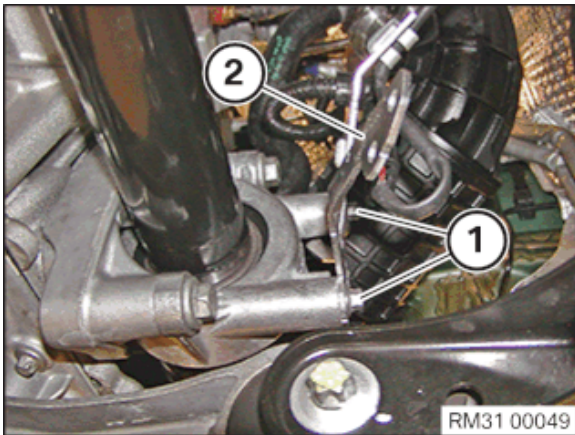

- If necessary, unscrew the bolts (1) and remove the holder (heat shield) (2).

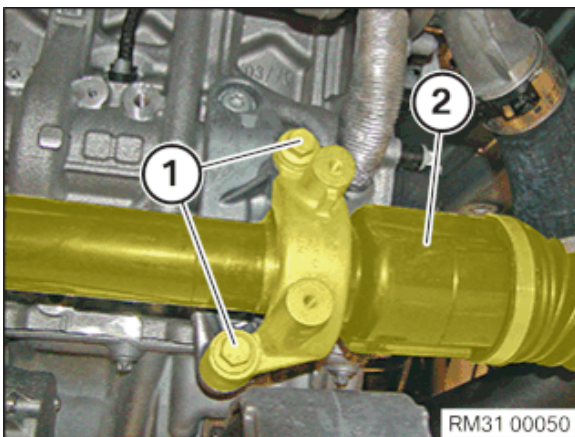

- Loosen screws (1).
- Pull out the output shaft (2) from the transmission.
- Tie up output shaft (1).

► Remove the left/right radial shaft seal on the differential (manual gearbox)



**Materials harmful to health.**

**Contact with fluids harmful to health!**

- Note and follow safety information on containers.
- Conduct all work in appropriate personal protective equipment only.



### Damage to the transmission.

#### Damage to the transmission by unapproved transmission oil.

- Use only the approved transmission oil.
- Check the transmission oil level after completing the repair.

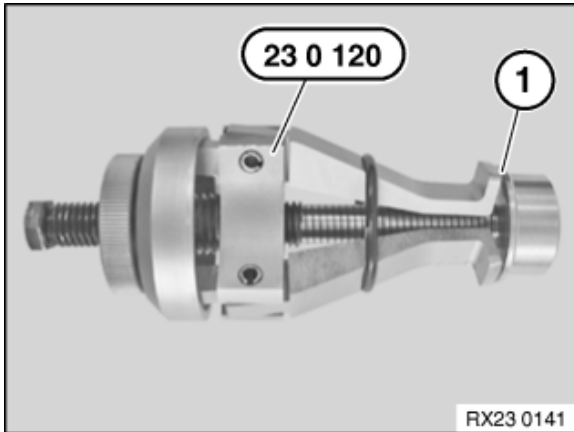

- Prepare special tool **0 496 698 (23 0 120)**.  
The distance (1) must be  $< 1$  mm.

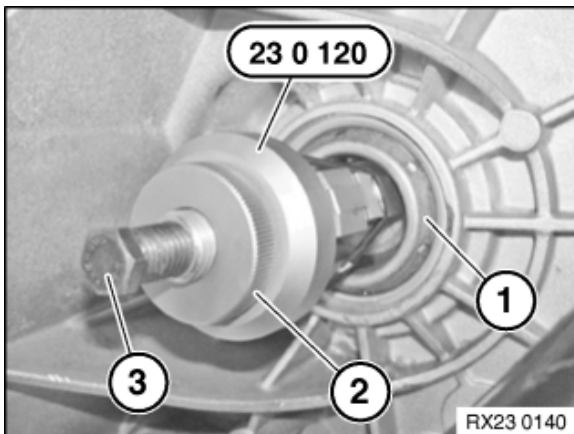

- Insert special tool **0 496 698 (23 0 120)** in the radial shaft seal (1) up to the limit position.
- Spread out the claws by turning the nut (2).
- Screw in screw (3) and pull off the radial shaft seal.

### 40 – Partially removing the left output shaft

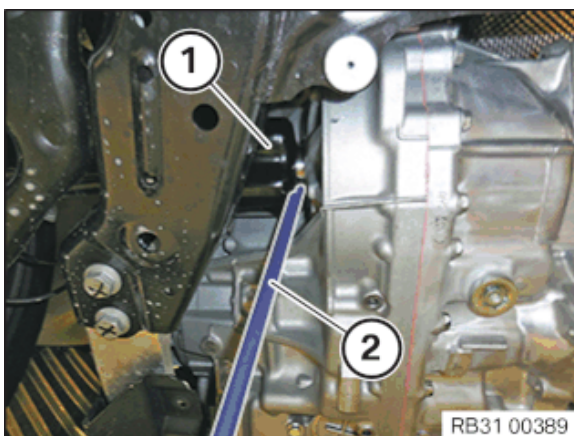

- Protect the output shaft (1) from falling.
- Lever out the output shaft (1) with a mounting lever (2) from the transmission.
- Tie up output shaft (1).

► Remove the left/right radial shaft seal on the differential (manual gearbox)



**Materials harmful to health.**

**Contact with fluids harmful to health!**

- Note and follow safety information on containers.
- Conduct all work in appropriate personal protective equipment only.



**Damage to the transmission.**

**Damage to the transmission by unapproved transmission oil.**

- Use only the approved transmission oil.
- Check the transmission oil level after completing the repair.

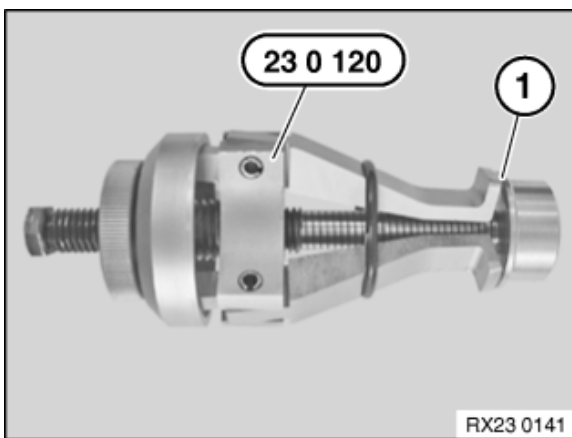

- Prepare special tool **0 496 698 (23 0 120)**.  
The distance (1) must be  $< 1$  mm.

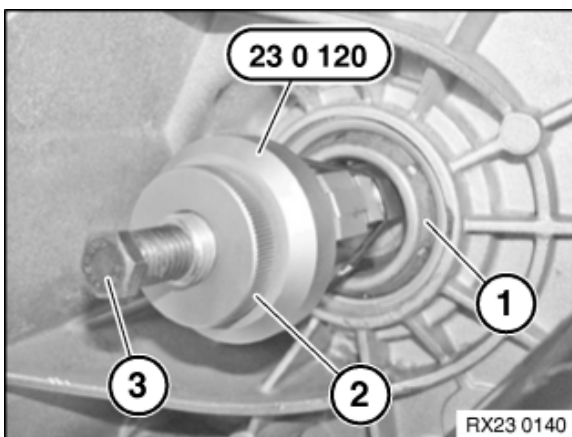

- Insert special tool **0 496 698 (23 0 120)** in the radial shaft seal (1) up to the limit position.
- Spread out the claws by turning the nut (2).
- Screw in screw (3) and pull off the radial shaft seal.

#### 41 – Remove the left/right radial shaft seal on the differential (manual gearbox)



**Materials harmful to health.**

**Contact with fluids harmful to health!**

- Note and follow safety information on containers.
- Conduct all work in appropriate personal protective equipment only.



### Damage to the transmission.

#### Damage to the transmission by unapproved transmission oil.

- Use only the approved transmission oil.
- Check the transmission oil level after completing the repair.

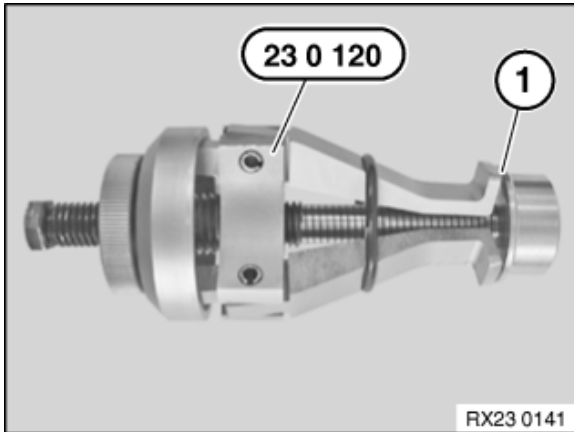

- Prepare special tool **0 496 698 (23 0 120)**.  
The distance (1) must be  $< 1$  mm.

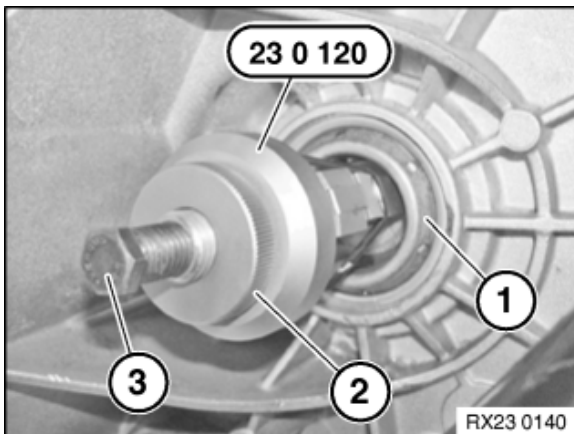

- Insert special tool **0 496 698 (23 0 120)** in the radial shaft seal (1) up to the limit position.
- Spread out the claws by turning the nut (2).
- Screw in screw (3) and pull off the radial shaft seal.

## 42 – Drawing off the air conditioning

### Prerequisite

The engine is switched off.



### Refrigerant circuit under high pressure.

#### Danger of injury!

- Note and follow safety information on containers.
- Avoid contact with refrigerant; wear safety goggles and protective gloves.
- For additional information see: 64 50 Handling refrigerant and 6450 Notes on air conditioning repair work



If the A/C service station for the R1234yf refrigerant identifies contaminated refrigerant in the refrigerant circuit of the vehicle before evacuation, then a special procedure to draw off and dispose of this refrigerant must be followed (see additional information).

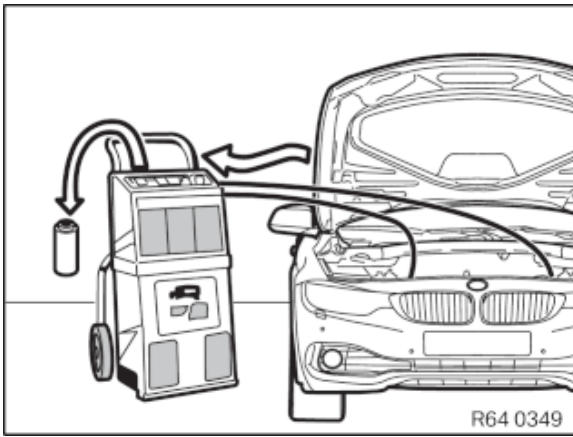

- Let the engine run for a few minutes at a low engine speed (800-1200 rpm) and with the heating and air conditioning system switched on.
- Stop engine.
- Remove the sealing caps from the refrigerant filler necks.
- Connect the high pressure line of the A/C service station with the vehicle's high-pressure connection (red).
- Connect the low-pressure line of the A/C service station with the vehicle's low-pressure connection (blue).
- Start the evacuation on the A/C service station.
- During evacuation, allow the blower of the heating and air-conditioning unit to run at middle blower speed.
- Record the amount of evacuated refrigerant and amount of refrigerant oil after having completed evacuation.
- Keep the sheet with the recorded quantities as the values are once again required when filling.
- Disconnect the high pressure line and low pressure line.
- Drain the high pressure line and low pressure line.
- Close the sealing cap of the coolant filler neck.
- Correctly dispose of the drained refrigerant oil.

## 43 – Evacuating the air conditioning

### Prerequisite

The engine is switched off.

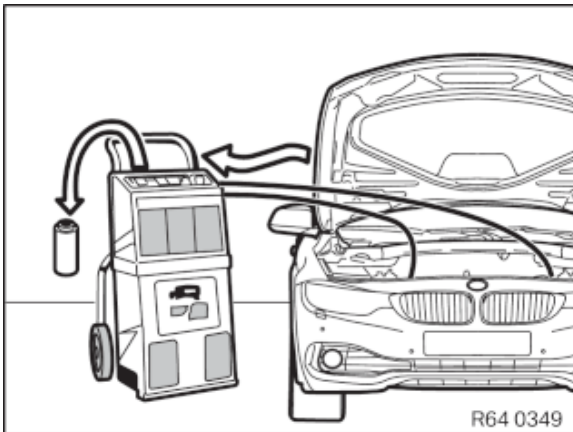

- Remove the sealing caps from the refrigerant filler necks.
- Connect the high pressure line of the A/C service station with the vehicle's high-pressure connection (red).
- Connect the low-pressure line of the A/C service station with the vehicle's low-pressure connection (blue).
- Start the evacuation on the A/C service station.
- Adhere to an evacuation time of **at least 30 min** .
- During evacuation, allow the blower of the heating and air-conditioning unit to run at middle blower speed.
- If the vacuum does not remain stable during evacuation:
  - Run the ABL for leaks in the refrigerant circuit.
  - Rectify leaks in the refrigerant circuit.

## MAIN WORK

---

## 44 – Removing engine

---

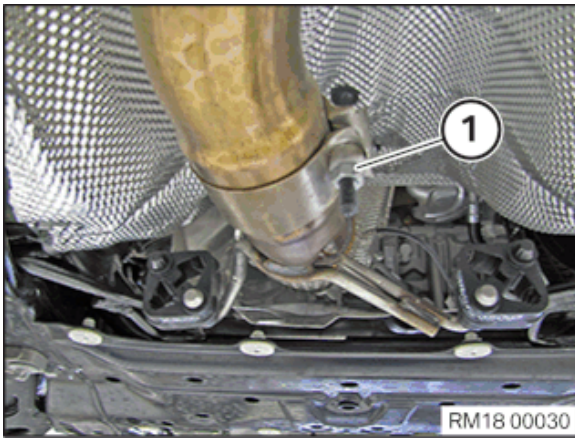

- Detach the ribbon clamp (1).

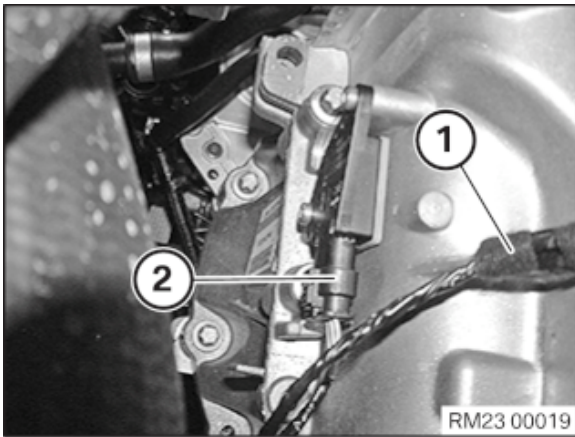

- Unlock and release the plug connection (2) on the gear sensor.
- Loosen the holder (1).

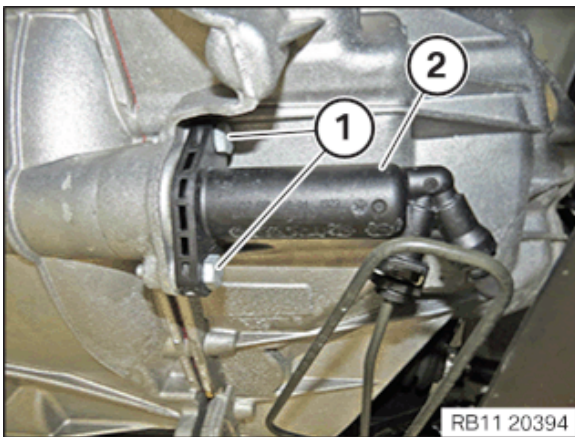

- Loosen screws (1).
- Feed out the clutch slave cylinder (2) and set it aside.

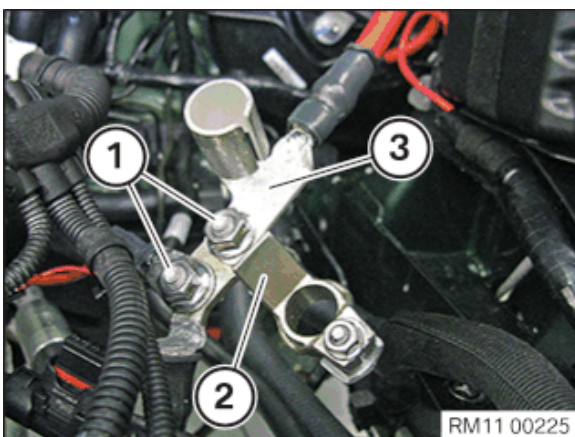

- Loosen nuts (1).
- Feed out the positive battery terminal (2) and the remote positive terminal (3) and set aside.

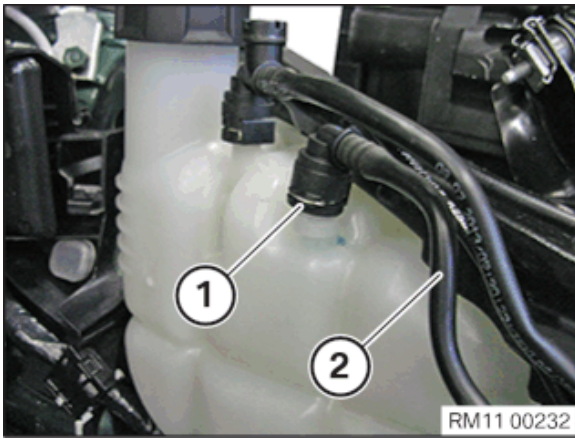

- Unlock and loosen lock (1).
- Feed out coolant line (2) and place to one side.

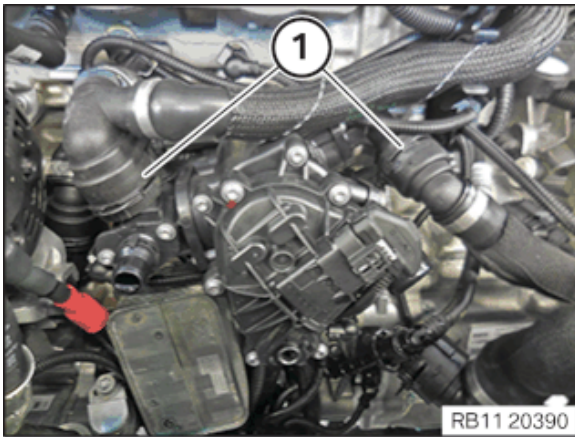

- Unlock and release coolant line (1).
- Catch and dispose of escaping coolant.

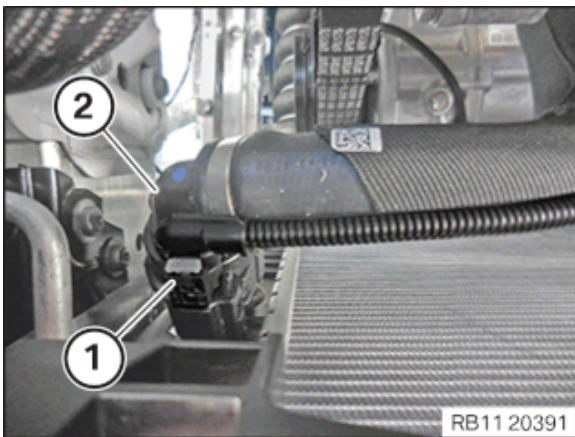

- Unlock plug connection (1) and disconnect.
- Unlock and disconnect the coolant line (2).
- Catch and dispose of escaping coolant.

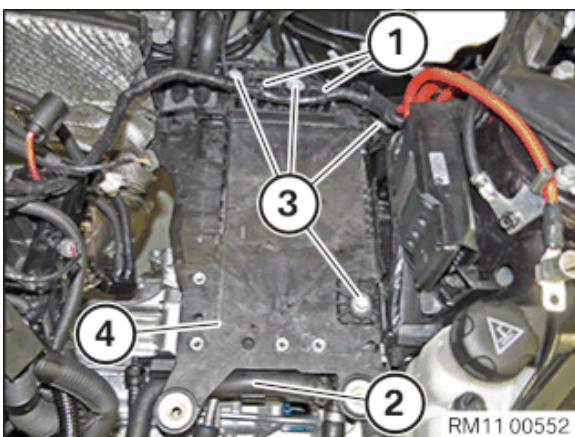

- Loosen clamps (1).
- Feed out the coolant line (2) from the battery tray (4) and set it aside.
- Loosen screws (3).
- Guide out the battery tray (4) and remove it.

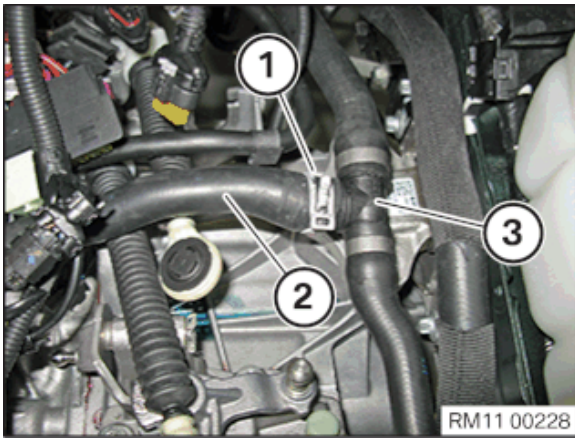

- Detach the clamping collar (1).
- Detach the coolant hose (2) from the coolant line (3).
- Catch and dispose of escaping coolant.

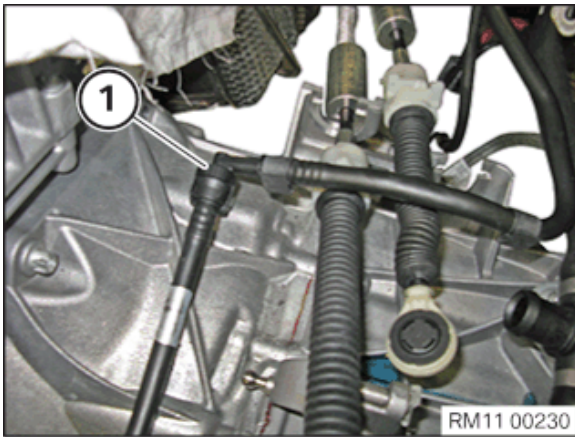

- Unlock and disconnect the vacuum line (1).

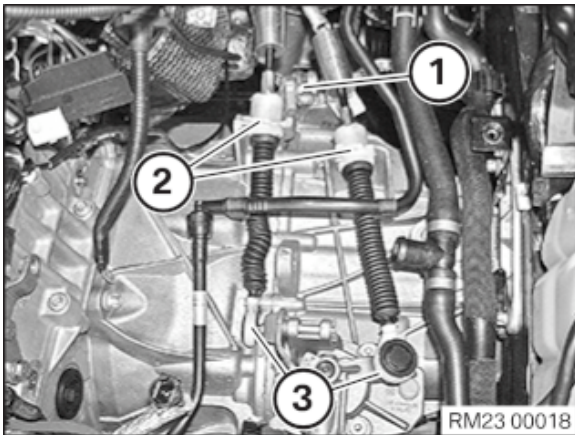

- Unscrew the bolt (1) and set the ground strap aside.
- Unlock and loosen holder (2).
- Detach the selector lever cable (3) at the ball joints and set it aside.

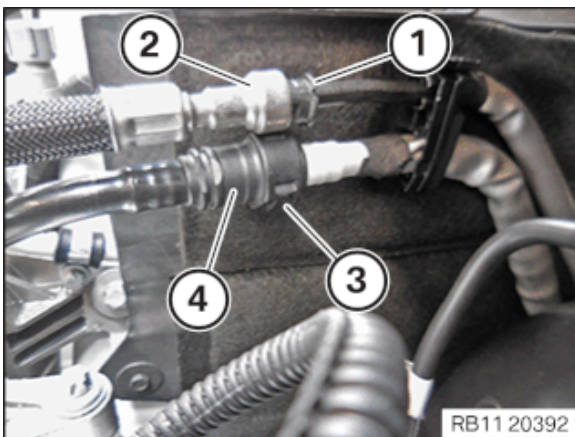

- Unlock lock (1).
- Guide the fuel feed line (2) out and set it aside.
- Catch and dispose of escaping fuel.
- Unlock lock (3).
- Feed the tank ventilation line (4) out and set it aside.

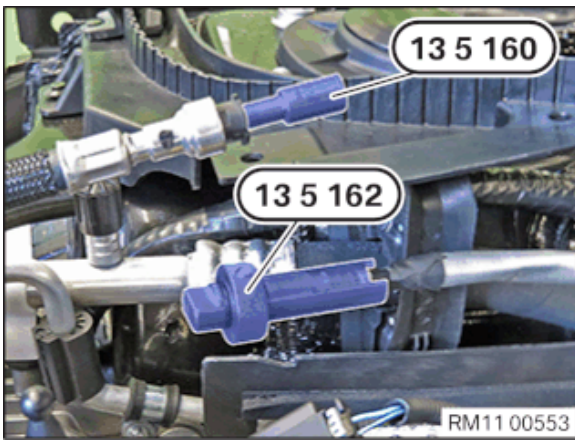

- Seal fuel lines with special tools **0 496 565 (13 5 160)** and **0 496 568 (13 5 162)**.

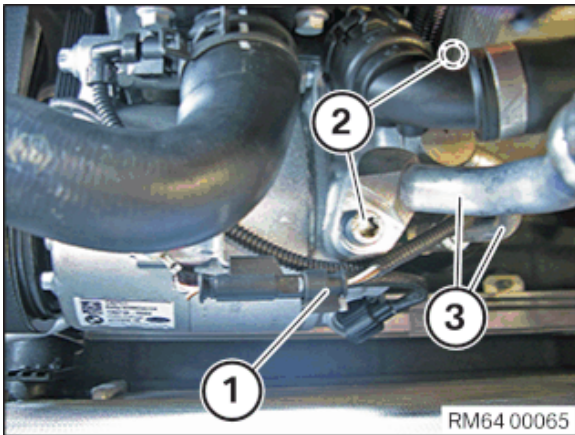

### Residual pressure in the air conditioning.

#### Danger of injury!

- Wear safety goggles and protective gloves when disconnecting the refrigerant line.
  - Seal refrigerant lines with seal plugs.
- Unlock plug connection (1) and disconnect.
  - Loosen screws (2).
  - Feed out the refrigerant lines (3) and set them aside.
  - Close the openings on the refrigerant lines (3) and the air conditioning compressor with standard tools.
  - Ensure that the **40/50** distance pins of table top **A** of the mobile lifting table are installed in mounting points (1) of the oil sump.

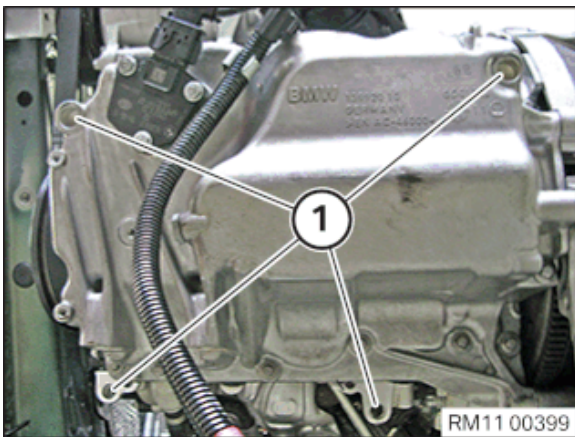

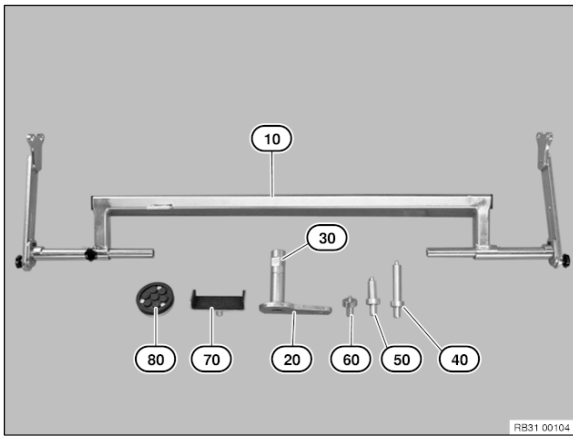

- Have the set of special tools **2 305 379** ready:

Number	Description
10	For mounting the swivel bearing including brake disc
20	Retaining element for adjustable fixture
30	Adjustable fixture
40	Distance pin 40 x 160 mm
50	Distance pin 40 x 110 mm
60	Distance pin 40 x 60 mm
70	Fixture with U-profile
80	Plate mounting 100 mm

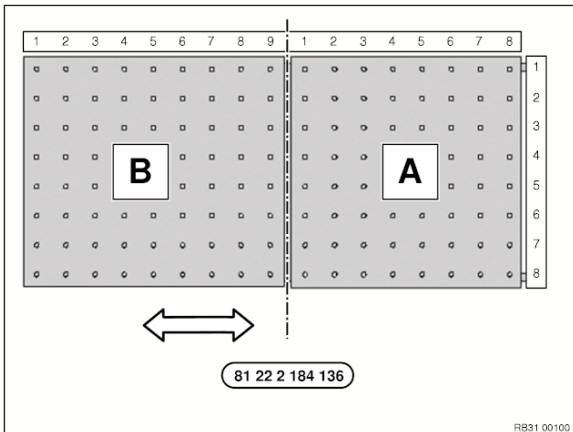

- Have the special tool **2 184 136** ready:

Letter	Description
A	Table top for engine with coordinates
B	Table top for transmission with coordinates

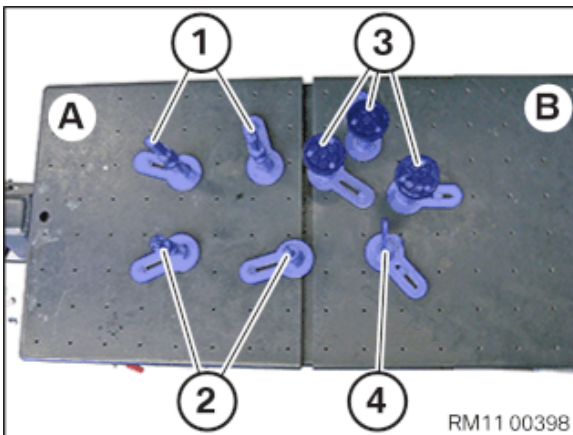

- Position the adjustable mounting (30) with a spacer pin (40) for the engine block on the table top (A) at the coordinates **5/6** and **1/7** (1).
- Position adjustable mounting (30) with the spacer pins (50) for the engine oil sump on table top (A) at coordinates **5/3** and **2/3**(2).
- Position adjustable mounting (30) with spacer pin(80) for the transmission housing on the table top (B) at coordinates **6/5**, **2/5** and **2/7**(3).
- Position the adjustable mounting **2 357 221** for the transmission housing on the table top (B) at coordinates **7/3**(4).

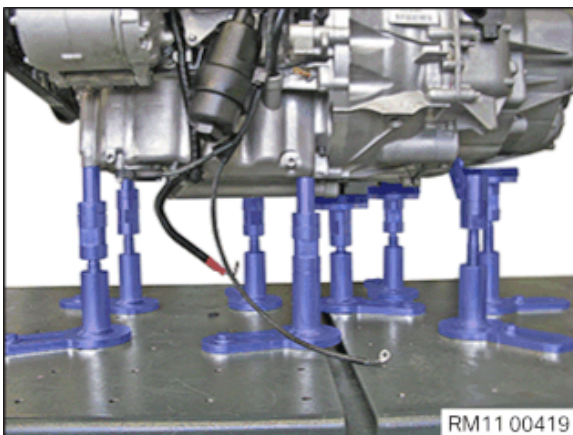

- Position the lifting table below the engine.
- Abut all fixtures and screw them to the lifting table.

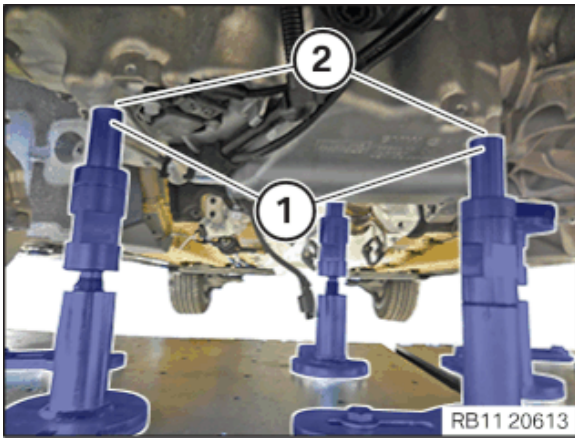

- Make sure that the spacer pins (1) are correctly positioned in the mountings (2) of the engine oil sump.

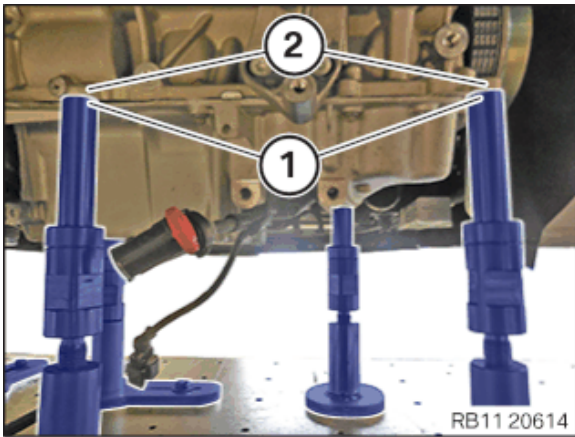

- Make sure that the spacer pins (1) are correctly positioned in the mountings (2) of the crankcase.

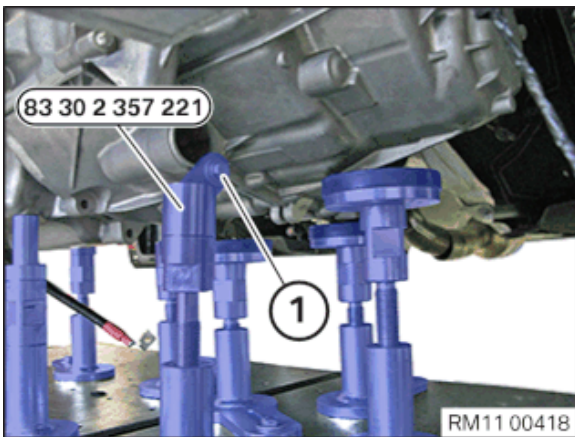

- Screw the adjustable mounting **2 357 221** with the screw (1) on to the housing of the clutch slave cylinder.

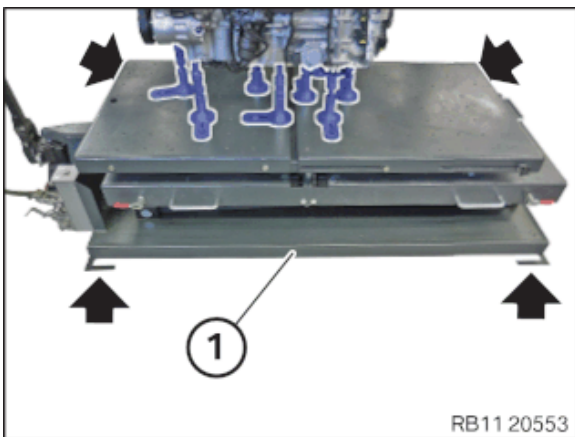

- Mark the position of the lifting table (1) on the workshop floor (arrows).

The marks (arrows) make the installation easier.

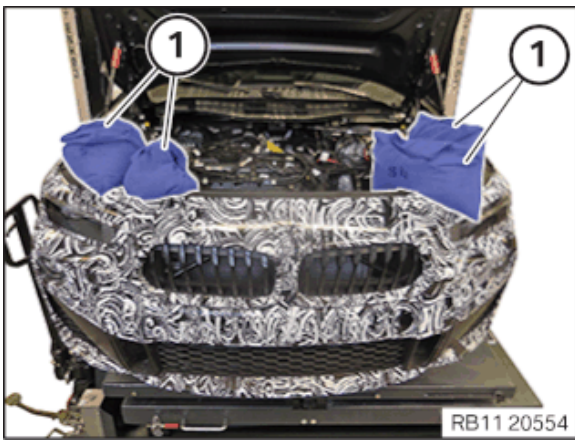

**Motor vehicle may slip off the vehicle hoist if the weight is distributed unevenly.**

**Danger! Life-threatening injuries!**

- Ensure there is a specific weight compensation on the motor vehicle.

- Position the weight compensation (1) on the vehicle.

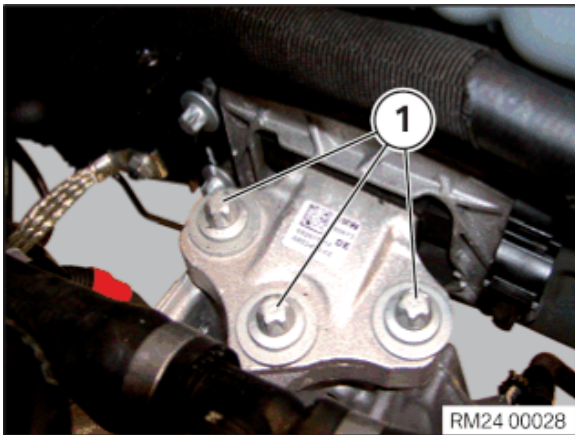

**Motor vehicle may slip off the vehicle hoist if the weight is distributed unevenly.**

**Danger! Life-threatening injuries!**

- Ensure there is a specific weight compensation on the motor vehicle.

- Loosen screws (1).

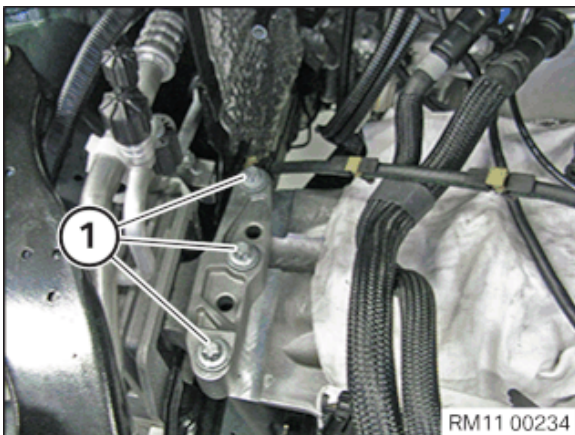

**Vehicle may slip off the vehicle hoist if the vehicle hoist is handled incorrectly.**

**Danger! Life-threatening injuries!**

- Observe safety information on raising the vehicle using a vehicle hoist.
- For additional information see: 00 ... Raise the vehicle using a vehicle lift.

- Loosen screws (1).
- Raise the vehicle **carefully**.

## 45 – Install engine

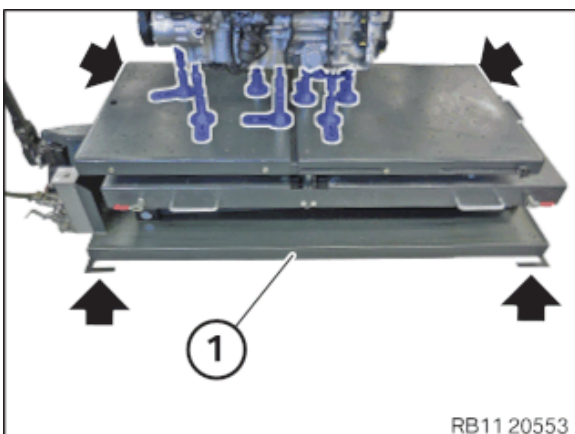

- Position the lifting table (1) with the engine under the vehicle.

The marks (arrows) that were made on the workshop floor during the disassembly serve as positioning aids.

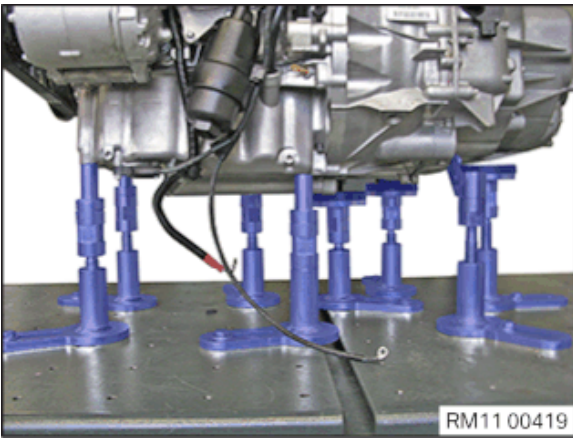

**Vehicle may slip off the vehicle hoist if the vehicle hoist is handled incorrectly.**

**Danger! Life-threatening injuries!**

- Observe safety information on raising the vehicle using a vehicle hoist.
- For additional information see: 00 ... Raise the vehicle using a vehicle lift.

- Lower the vehicle **carefully**, **correct** the positioning of the lifting table if necessary.

- Renew screws (1).

**Parts:** Bolts

- Tighten the screws (1).

#### Transmission mounting

M10	Renew screws.	Jointing torque	40 Nm
		Angle of rotation	90 °

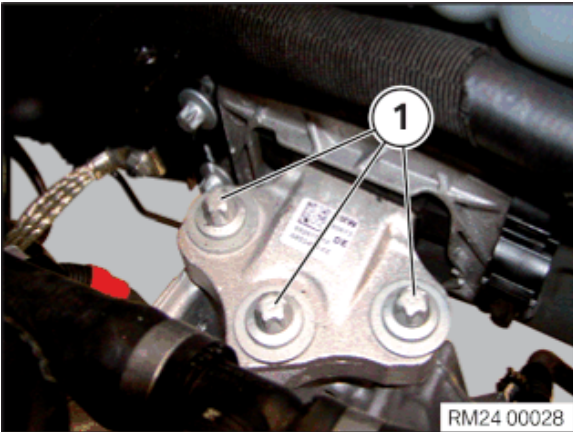

- Renew screws (1).

**Parts:** Bolts

- Tighten the screws (1).

#### Right engine mount to cylinder head

M10	Renew screws.	Jointing torque	40 Nm
		Angle of rotation	90 °

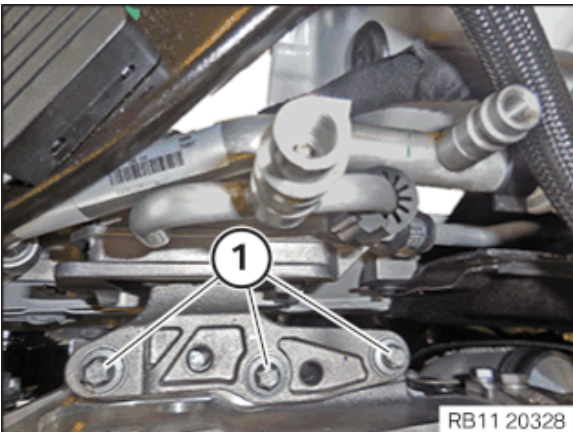

**Motor vehicle may slip off the vehicle hoist if the weight is distributed unevenly.**

**Danger! Life-threatening injuries!**

- Ensure there is a specific weight compensation on the motor vehicle.

- Remove weight compensation (1) from the vehicle.

- Lower lifting table(2) and put to one side.

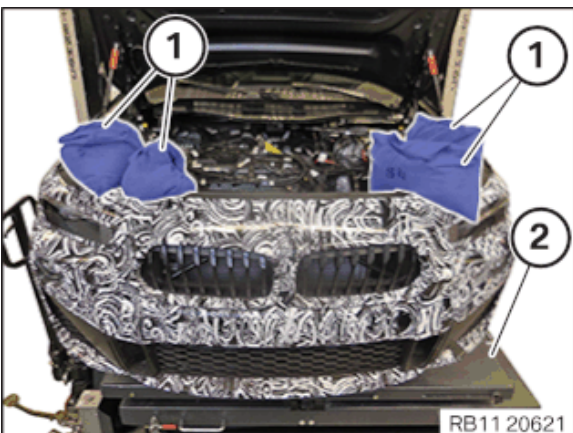

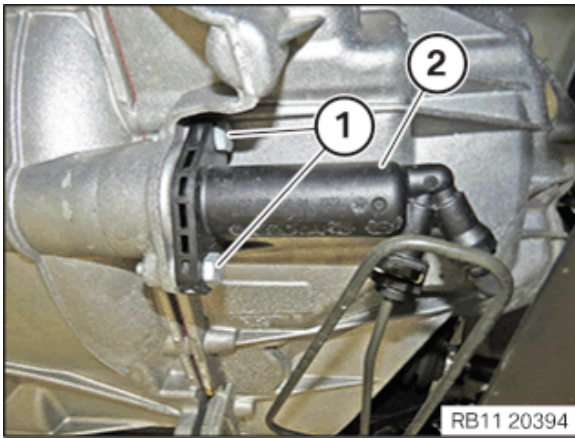

- Feed in and install the clutch slave cylinder (2).
- Tighten the screws (1).

#### Clutch slave cylinder to transmission housing

M8

Tightening  
torque

19 Nm

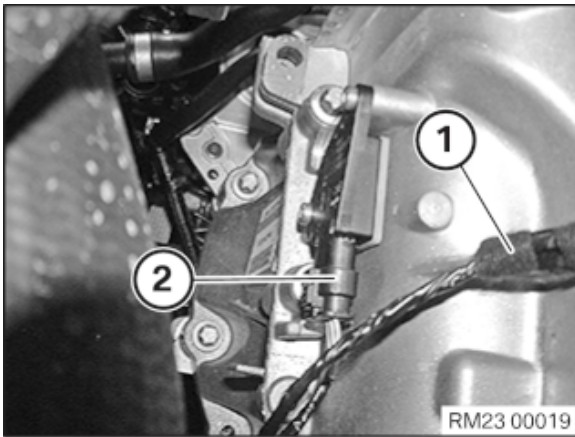

- Connect and lock connector (2) on the gear sensor.
- Make sure the connector (2) engages audibly.
- Secure the holder (1).

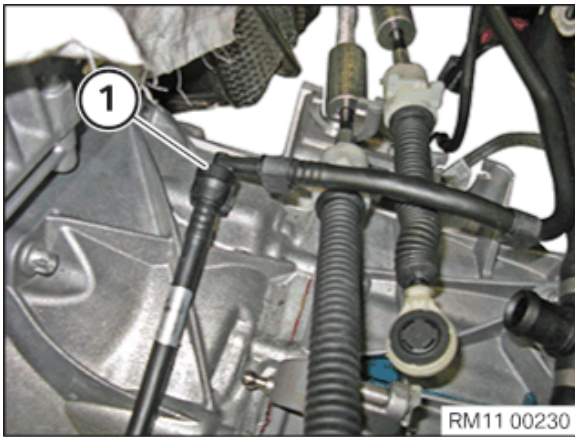

- Connect the vacuum line (1) and lock.
- Make sure you can hear the vacuum line (1) engage.

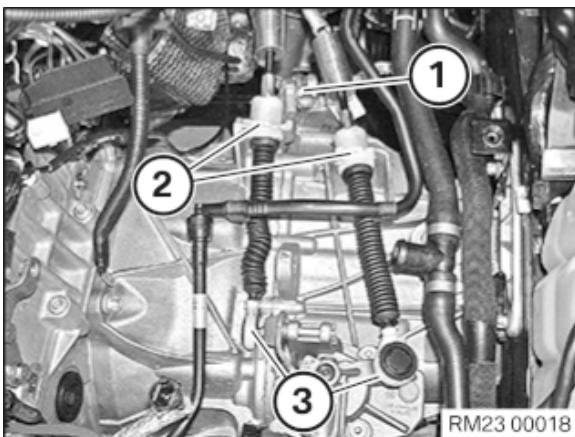

- Feed in and install the ground strap.
- Tighten down screw (1).
- Feed in and install the selector lever cables (3) at the ball joints.
- Make sure you can hear the selector lever cables (3) engage.
- Insert and install the holder (2).
- Make sure you can hear the holders (2) engage.

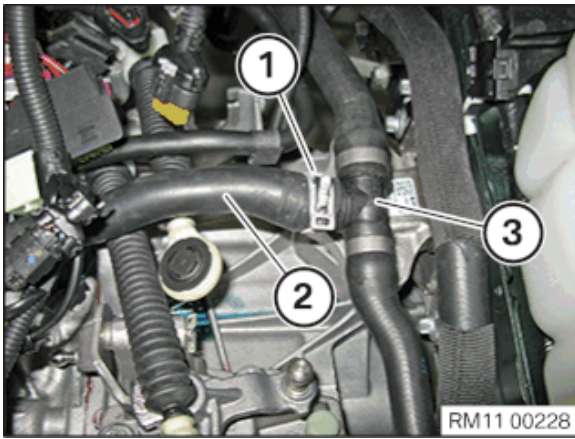

- Insert and install the coolant hose (2) on the coolant line (3).
- Fasten the clamping collar (1).

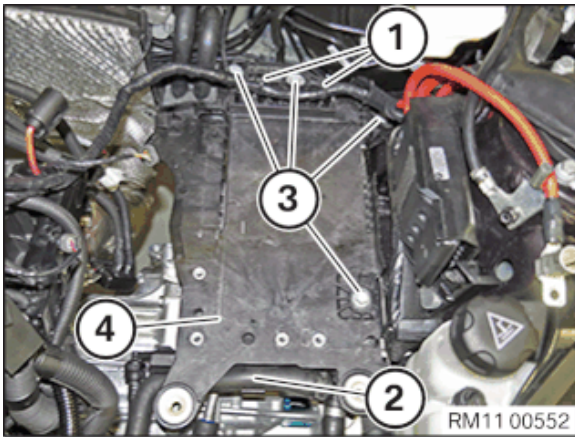

- Guide out the battery tray (4) and remove it.
- Feed in and install coolant line (2) on the battery tray (4).
- Secure clamps (1).
- Tighten down screws (3).

#### Battery tray

M8	Tightening torque	19 Nm
----	-------------------	-------

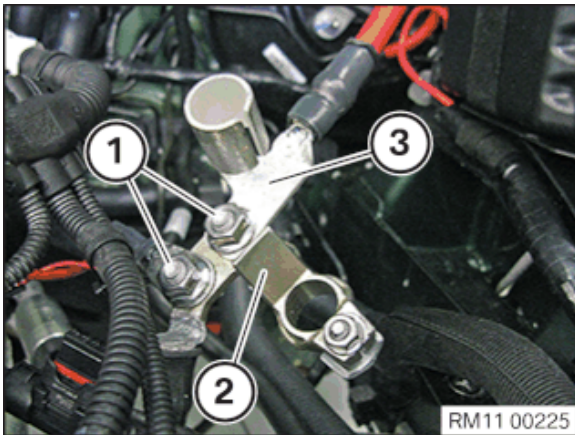

- Insert and install the positive battery terminal (2) and the remote positive terminal (3).
- Tighten nuts (1).

#### Positive battery cable to positive battery terminal

M8	Tightening torque	15 Nm
----	-------------------	-------

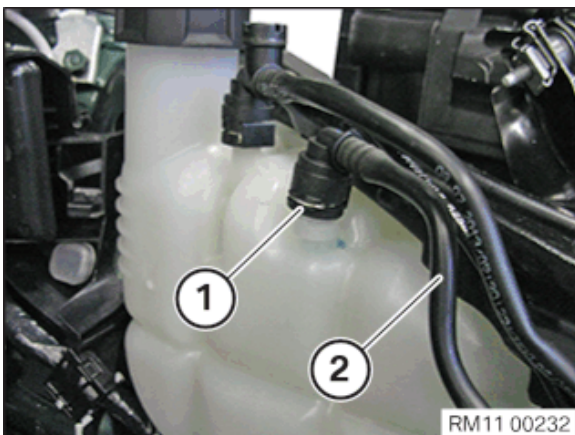

- Feed in and install coolant line (2).
- Ensure that the lock (1) engages audibly.

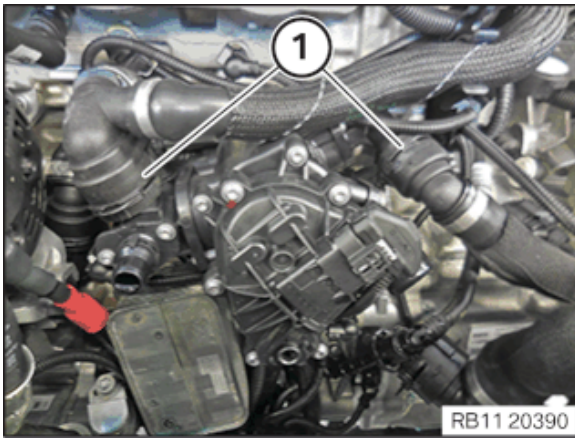

- Connect and lock the coolant lines (1).
- Make sure that you can hear the coolant lines (1) engage.

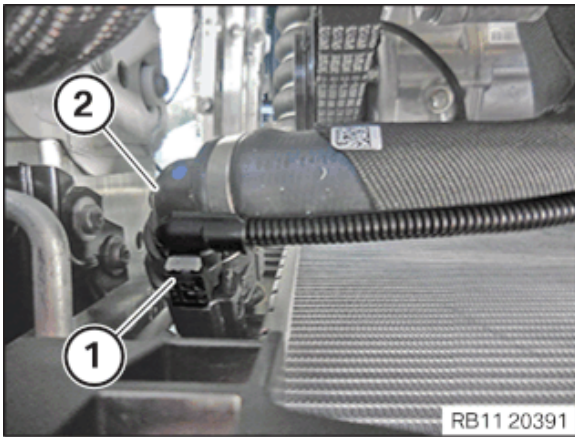

- Connect and lock coolant line (2).
- Make sure that the cooling line (2) engages audibly.
- Connect connectors (1) and lock.
- Make sure the connector (1) engages audibly.

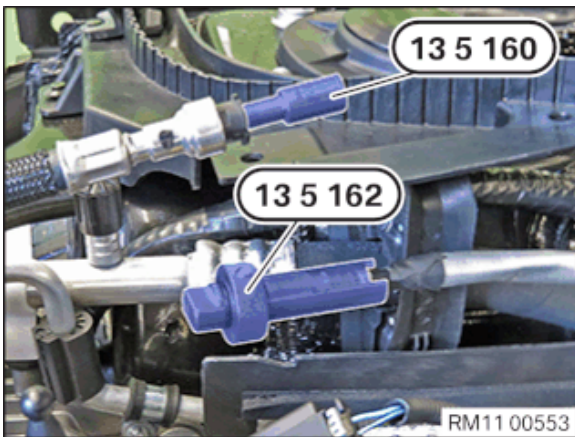

- Thread out special tools **0 496 568 (13 5 162)** and **0 496 565 (13 5 160)** and remove.

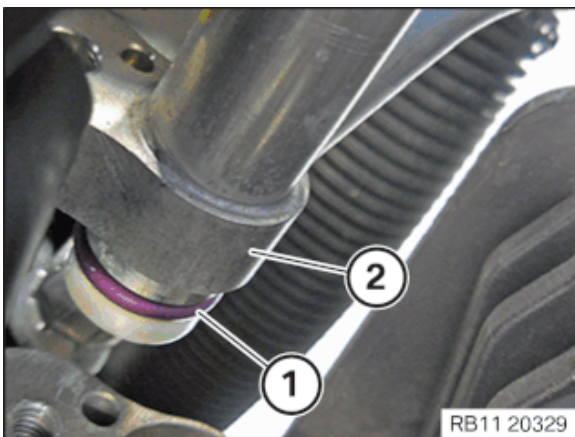

- Feed out and remove standard tools at the refrigerant lines (2) and the air conditioning compressor.

- Renew sealing ring (1).

**Parts:** Sealing ring

- Guide in the sealing ring (1) on the refrigerant line (2) and install.

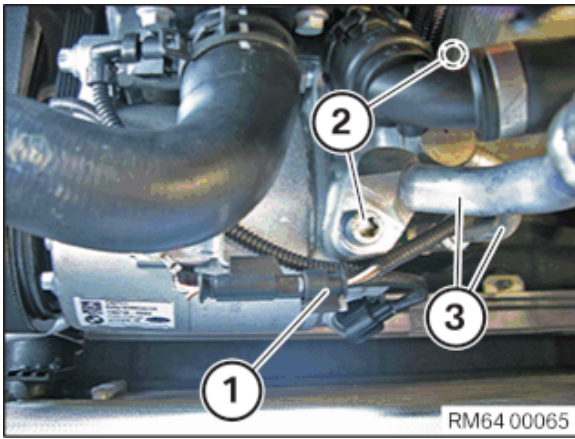

- Feed in and install the refrigerant lines (3).
- Tighten down screws (2).

#### Refrigerant lines to air-conditioning compressor

M8	Renew sealing rings.	Tightening torque	19 Nm
----	----------------------	-------------------	-------

- Connect connectors (1) and lock.
- Make sure the connector (1) engages audibly.

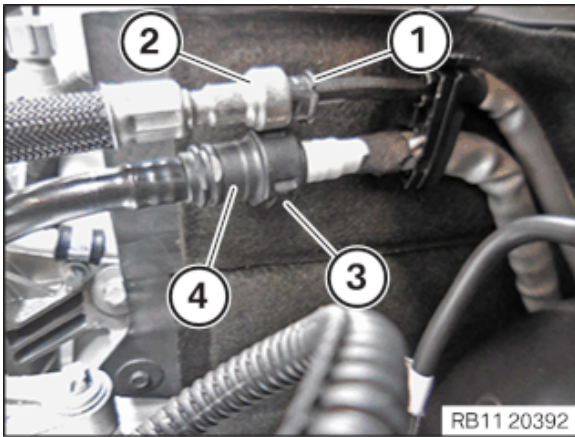

- Insert and install the tank ventilation line (4).
- Ensure that the lock (3) engages audibly.
- Guide the fuel delivery line (2) in and install.
- Ensure that the lock (1) engages audibly.

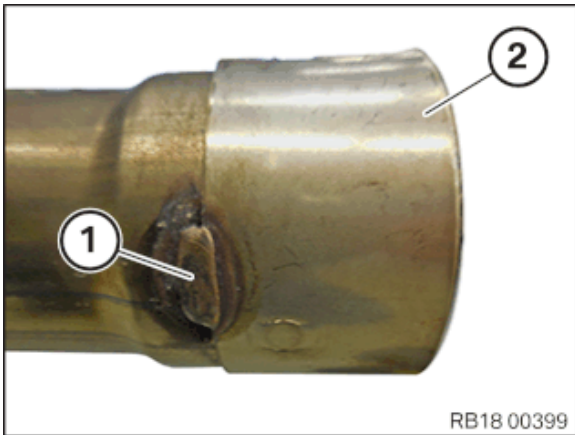

- Open the weld seam (1) with a conventional tool.
- Remove ribbon clamp (2).
- Renew the (2) ribbon clamp.

**Parts:** Ribbon cable clamp

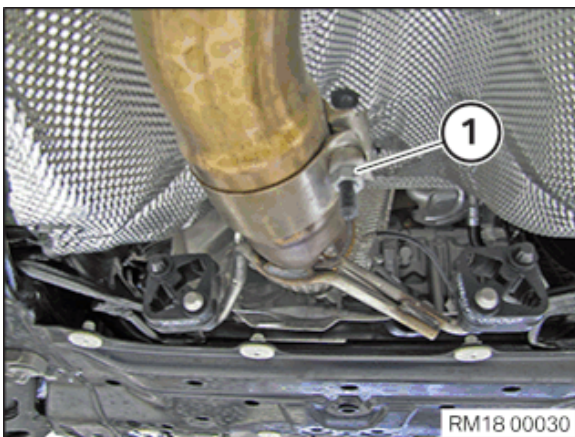

- Tighten the ribbon clamp (1).

#### Exhaust system to catalytic converter

Ribbon cable clamp	Renew flat band clip.	Tightening torque	26 Nm
--------------------	-----------------------	-------------------	-------

## POSTPROCESSES

### 46 – Installing the left radial shaft seal on the differential (manual gearbox)



**Materials harmful to health.**

**Contact with fluids harmful to health!**

- Note and follow safety information on containers.
- Conduct all work in appropriate personal protective equipment only.



**Damage to the transmission.**

**Damage to the transmission by unapproved transmission oil.**

- Use only the approved transmission oil.
- Check the transmission oil level after completing the repair.

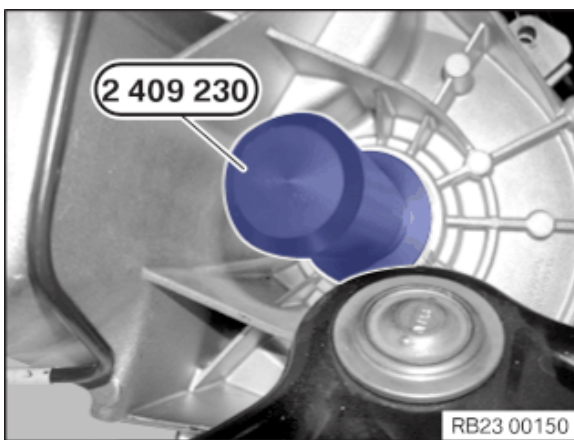

- Coat sealing lips of radial shaft seal with transmission oil.
- Drive the radial shaft seal into the housing with the special tool **2 409 230** until the sealing ring finishes flush with the transmission housing.

## 47 – Installing right output shaft partially

► **Installing the radial shaft seal, right in the differential (manual gearbox)**



**Materials harmful to health.**

**Contact with fluids harmful to health!**

- Note and follow safety information on containers.
- Conduct all work in appropriate personal protective equipment only.



**Damage to the transmission.**

**Damage to the transmission by unapproved transmission oil.**

- Use only the approved transmission oil.
- Check the transmission oil level after completing the repair.

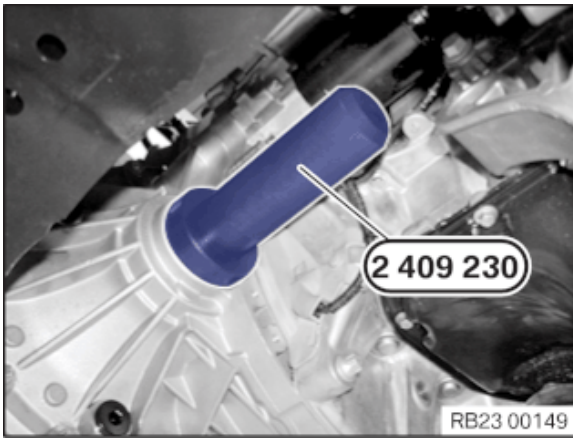

- Coat sealing lips of radial shaft seal with transmission oil.
- Drive the radial shaft seal into the housing with the special tool **2 409 230** until the sealing ring finishes flush with the transmission housing.

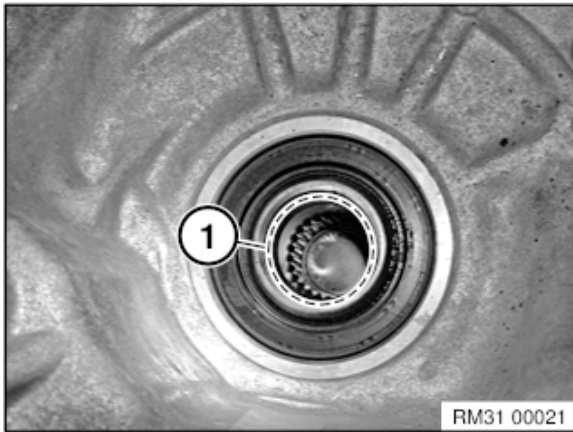

• **With automatic transmission only:**

- Lever out O-ring (1).
- Renew O-ring (1).

**Parts:** O-ring

- Insert new O-ring (1).

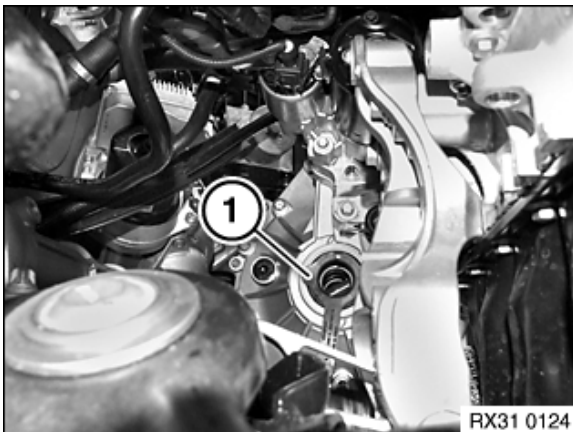

- Insert installation protection ring (1) into the radial shaft seal.
- Make sure the tool fits over the lip of the radial shaft seal so there is no damage to sealing ring when the output shaft is inserted.

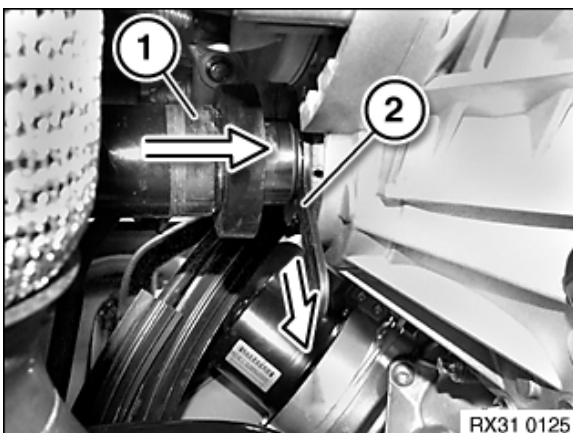

- Insert output shaft (1) into transmission.
- Pull on the handle to remove the installation protection ring (2) and dispose of it.
- Slide output shaft (1) into the transmission as far as the limit position.
- Check for secure seat by levering.

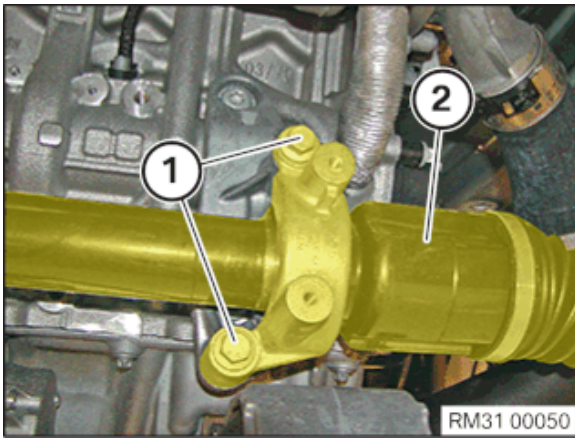

- Tighten the screws (1).

#### Output shaft bearing to engine block

M10	Tightening torque	38 Nm
-----	-------------------	-------

### 48 – Partially installing the left output shaft

- Installing the left radial shaft seal on the differential (manual gearbox)



**Materials harmful to health.**

**Contact with fluids harmful to health!**

- Note and follow safety information on containers.
- Conduct all work in appropriate personal protective equipment only.



**Damage to the transmission.**

**Damage to the transmission by unapproved transmission oil.**

- Use only the approved transmission oil.
- Check the transmission oil level after completing the repair.

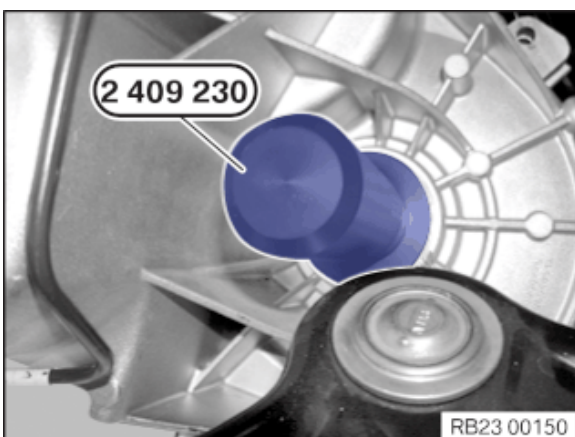

- Coat sealing lips of radial shaft seal with transmission oil.
- Drive the radial shaft seal into the housing with the special tool **2 409 230** until the sealing ring finishes flush with the transmission housing.



- **With automatic transmission only:**

- Lever out O-ring (1).
- Renew O-ring (1).

**Parts:** O-ring

- Insert new O-ring (1).

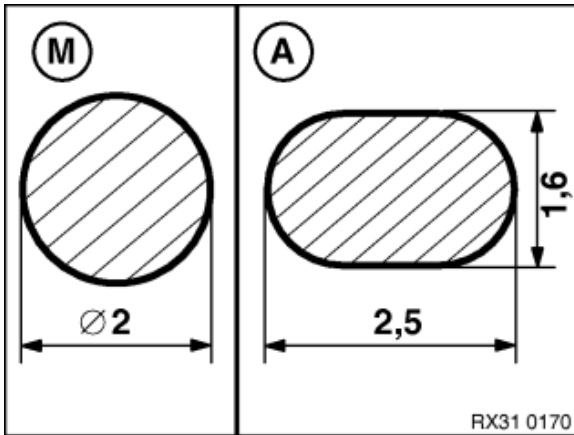

- Do not mix up circlips.

Different types of output shafts fitted:

- **M:** Manual transmission
- **A:** Automatic transmission

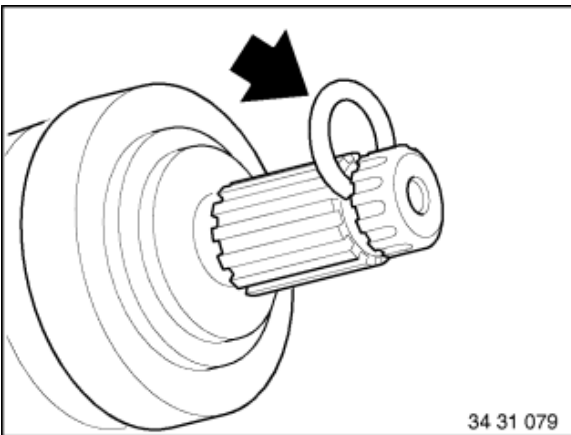

- Renew circlip (arrow).

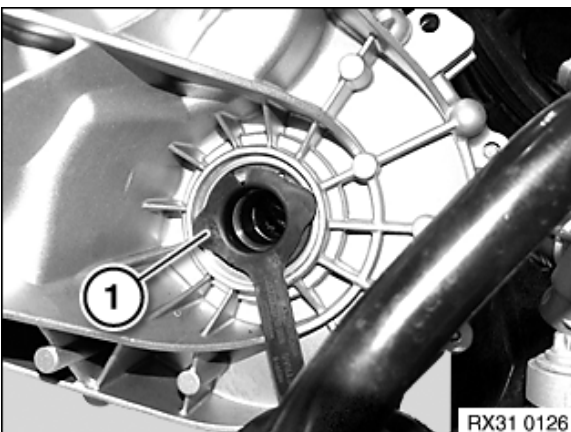

- Insert installation protection ring (1) into the radial shaft seal.
- Make sure the tool fits over the lip of the radial shaft seal so there is no damage to sealing ring when the output shaft is inserted.

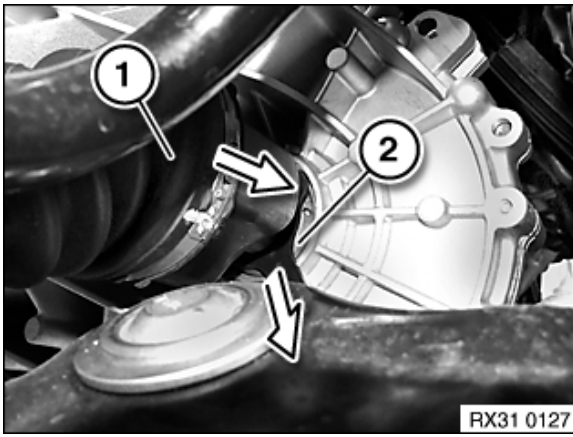

- Insert output shaft (1) into transmission.
- **Manual gearbox only:** Pull on the handle to remove the installation protection ring (2) and dispose of it.
- Slide output shaft (1) into the transmission as far as the limit position.  
The output shaft (1) must engage audibly.
- Check for secure seat by levering.

## 49 – Install pressure pipe between exhaust turbocharger and charge air cooler



### Damage to the exhaust turbocharger.

A leak at the pressure pipe can damage the exhaust turbocharger.

- Replace the gaskets and pressure pipe if necessary.

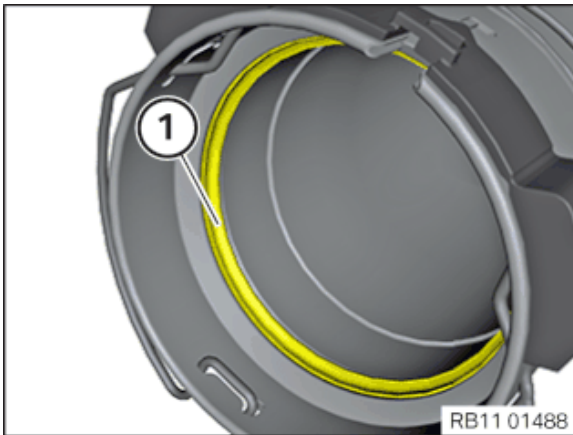

- Check the sealing ring (1) for damage and renew the sealing ring (1) as needed.

**Parts:** Gasket

## ► Replacing damaged seal



Do not use pointed or sharp-edged tools for the installation and/or removal.

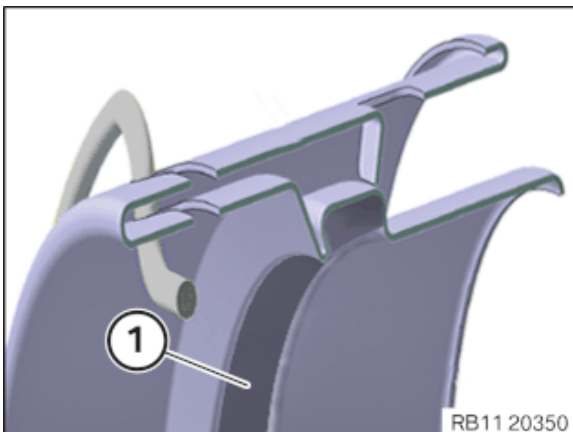

- Remove damaged seal.
- Clean gasket groove (1) with a dry towel.  
The gasket groove (1) must be clean.

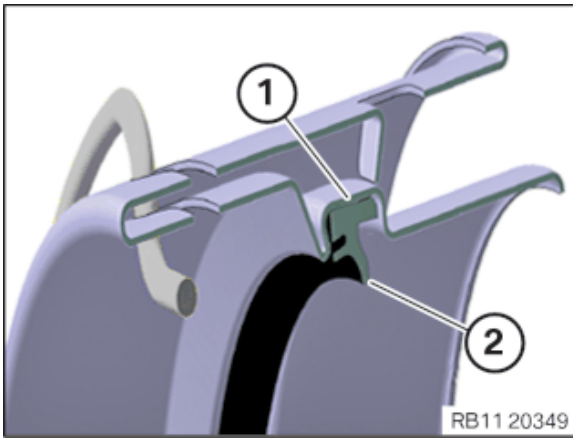

- Renew gasket.

**Parts:** Gasket

- Install seal dry without lubricant or mounting agent.



Incorrect assembly is possible. Ensure correct installation position.

- Feed in and install the seal.
- Make sure the seal is correctly installed in the gasket groove (1).
- Make sure that the sealing lip (2) is directed inwards as shown.

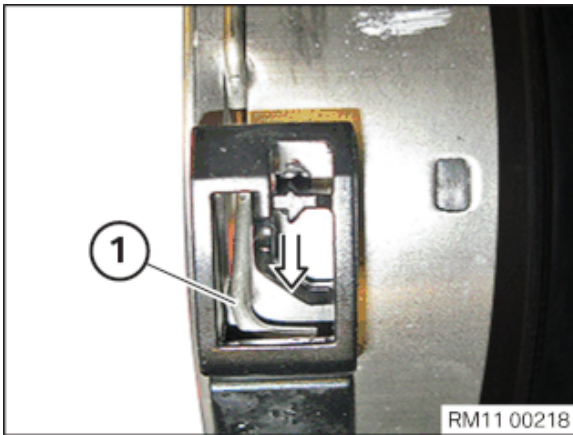

- Detach the locks (1) in the direction of the arrow from the brackets.
- Ensure that the locks (1) engage audibly.

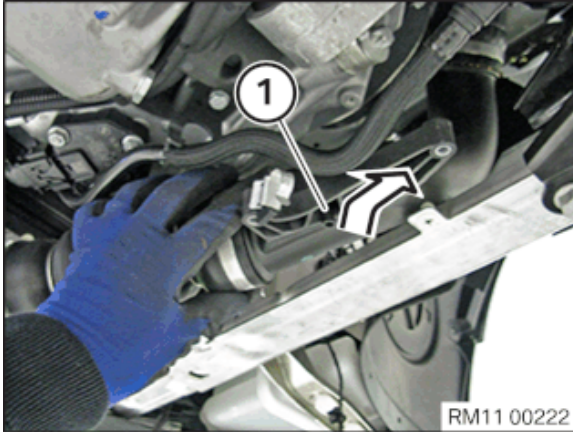

- Insert and install the pressure pipe (1) in the direction of the arrow.

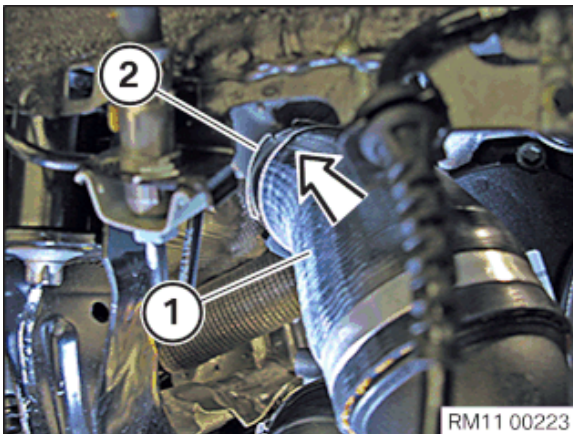

- Feed in the pressure pipe (1) in the direction of the arrow and install it on the exhaust turbocharger.
- Locks (2) must engage audibly.

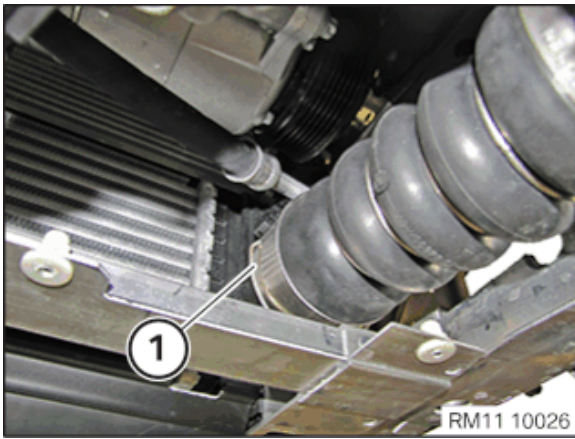

- Feed the pressure pipe (1) in at the charge air cooler and install it.
- Make sure the pressure pipe (1) engages audibly at the charge air cooler.

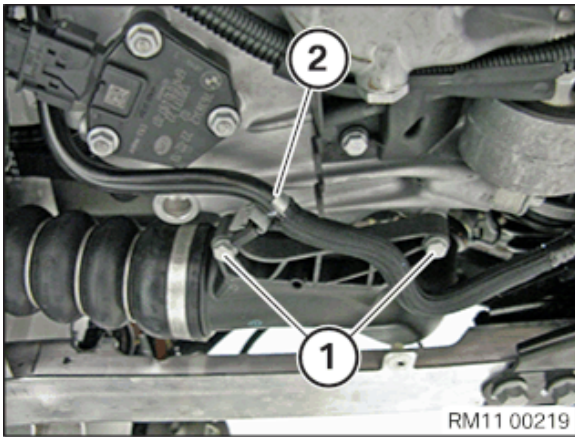

- Tighten the screws (1).

#### Charge air duct to oil sump

M6

Tightening torque

8 Nm

- Feed in and install the line (2).

## 50 – Installing pressure pipe between throttle body and charge air cooler



### Damage to the exhaust turbocharger.

**A leak at the pressure pipe can damage the exhaust turbocharger.**

- Replace the gaskets and pressure pipe if necessary.

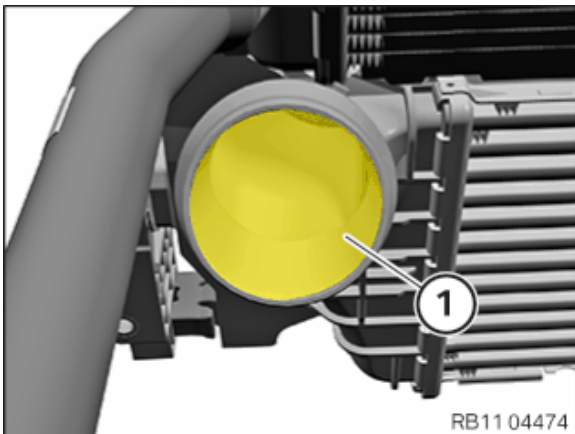

### Contaminant or foreign body.

**Contamination can result in malfunctions, operating failure or leaks.**

- Adhere to the utmost cleanliness.
  - Protect components from contamination e.g. by covering.
  - Close off line connections with seal plugs.
- Remove the auxiliary materials for locking the opening (1) of the charge air cooler.

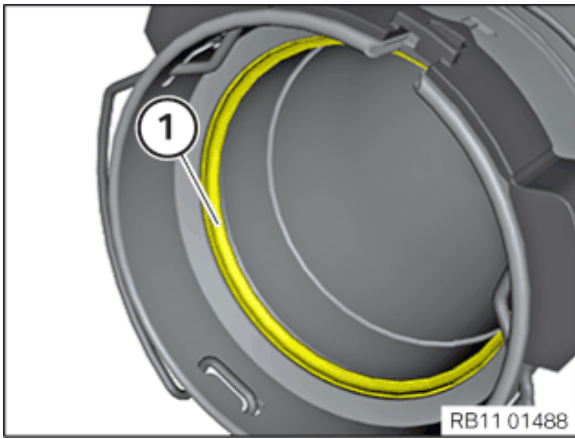

- Check seal (1) for damage and renew seal (1) as needed.

**Parts:** Gasket

### ► Replacing damaged seal

**i**

Do not use pointed or sharp-edged tools for the installation and/or removal.

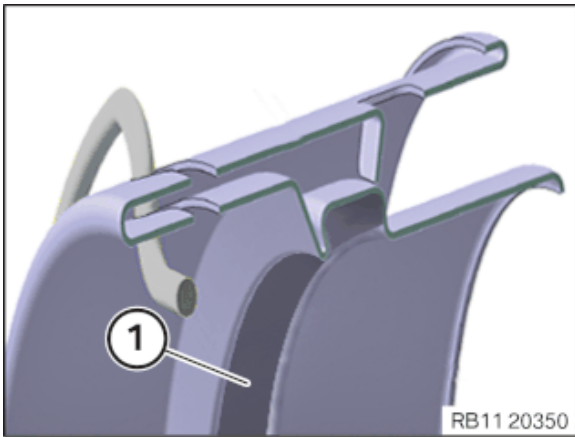

- Remove damaged seal.
- Clean gasket groove (1) with a dry towel.  
The gasket groove (1) must be clean.

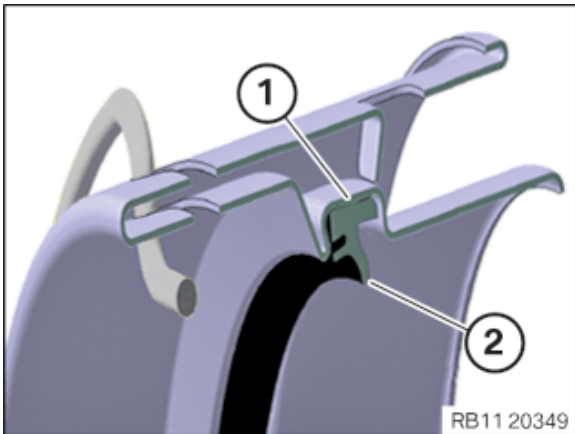

- Renew gasket.  
**Parts:** Gasket
- Install seal dry without lubricant or mounting agent.

**i**

Incorrect assembly is possible. Ensure correct installation position.

- Feed in and install the seal.
- Make sure the seal is correctly installed in the gasket groove (1).
- Make sure that the sealing lip (2) is directed inwards as shown.

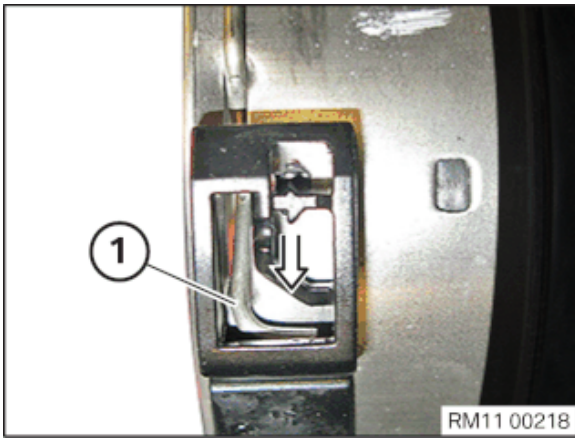

- Detach the locks (1) in the direction of the arrow from the brackets.

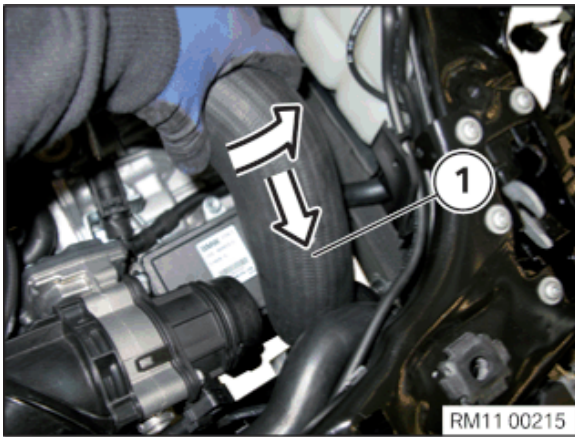

- Insert and install the pressure pipe (1) in the direction of the arrow.

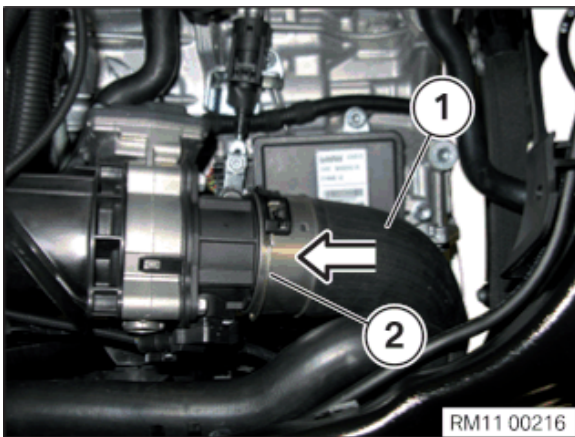

- Insert and install the pressure pipe (1) in the direction of the arrow.
- Ensure that the locks (1) engage audibly.

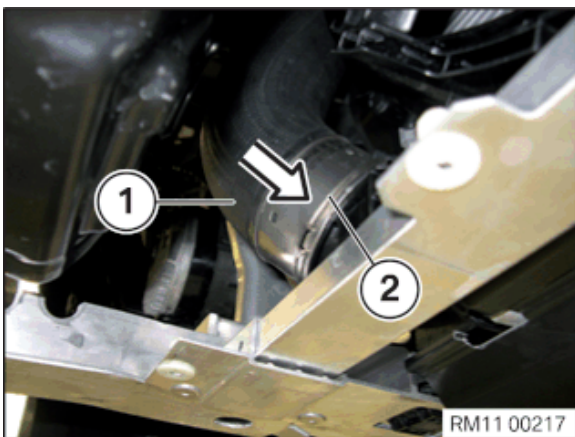

- Insert and install the pressure pipe (1) in the direction of the arrow.
- Ensure that the locks (2) engage audibly.

## 51 – Mount and secure the complete front axle

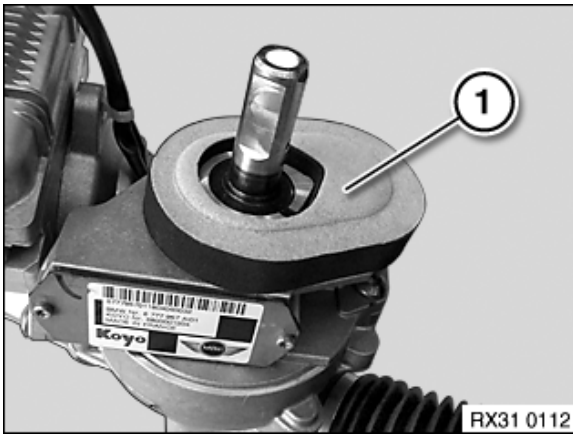

- Remove the sealing (1).
  - Clean surface on steering gear.
  - Renew the seal (1).
- Parts:** Gasket
- Position the seal (1) and glue it on.

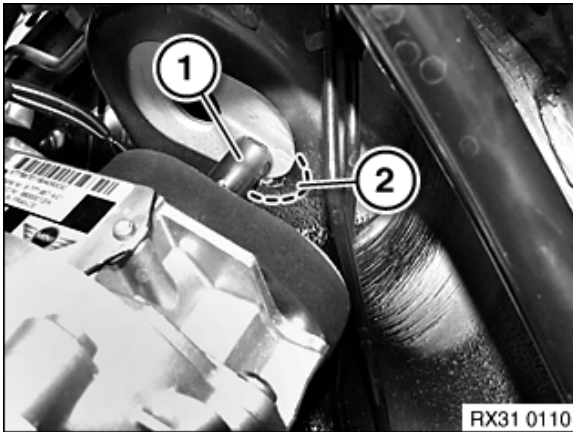

**Failure to comply with the specifications.  
Component damage.**

- All specifications for installation and removal **must** be observed.
- When lowering and raising the front axle support, make sure that the torsion bar (1) of the electromechanical steering gear (EPS) in the area (2) does not collide with the bulkhead!
- Note:** Collision with the bulkhead may result in damage to the electromechanical steering gear (EPS)!

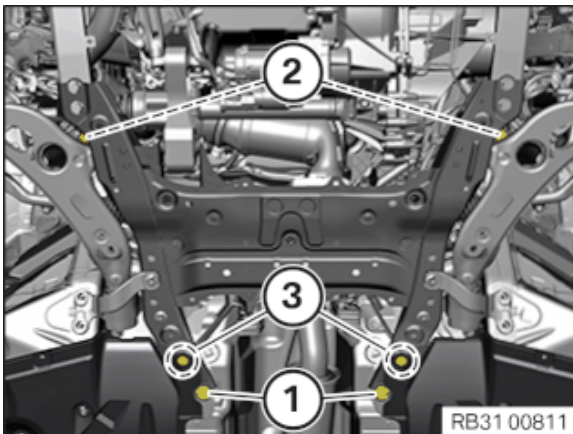

- Position front axle support.
- Bend underbody panellings in the areas (3) to one side.
- Raise front axle support.
- When raising, insert charge air cooler into the rubber mount of the charge air cooler on cross member.
- Renew screws (1) and (2).

**Parts:** Screws

- Tighten the screws (1).

**Rear end of front axle support to body**

M14 screw	Renew screw.	Tightening torque	175 Nm
-----------	--------------	-------------------	--------

- Tighten the screws (2).

**Front axle support, front to body**

M12 screw	Renew screw.	Tightening torque	108 Nm
-----------	--------------	-------------------	--------

- If necessary, tighten the screws in the areas (3).

**Underbody protection to body**

Screw		Tightening torque	3 Nm
-------	--	-------------------	------

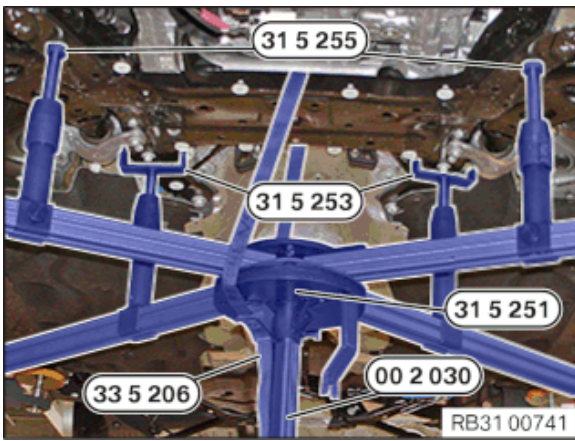

- Release the special tool **0 496 080 (33 5 206)** from the special tool **0 495 817 (31 5 251)**.
- Lower the universal jack **0 490 133 (00 2 030)** with the special tool **0 495 817 (31 5 251)** and set it aside.

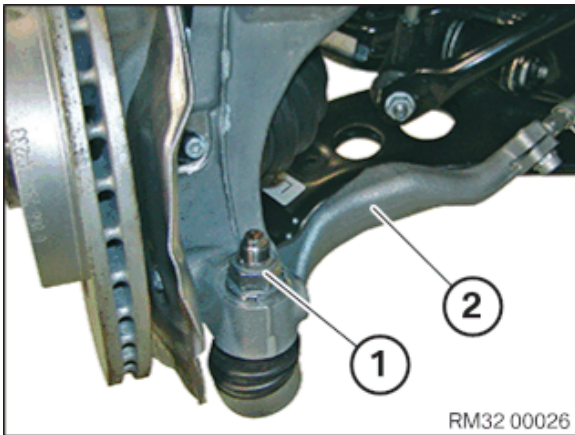

Perform the operations on the left and right side.

- Position the track rod (2) on the swivel bearing .
- Renew nut (1).

**Parts:** Nut

- Tighten nut (1).

#### Track rod end to swivel bearing

M14	Renew nut.	Tightening torque	175 Nm
-----	------------	-------------------	--------

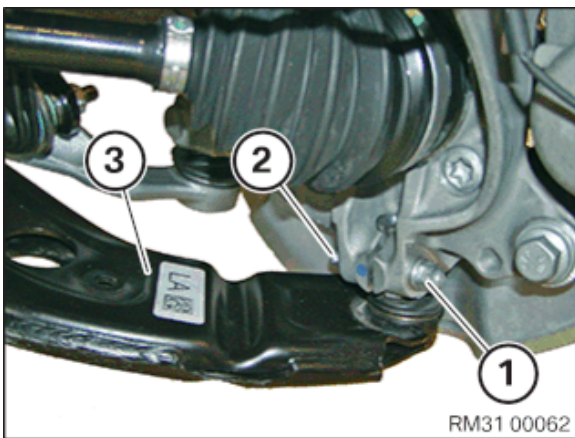

Perform the operations on the left and right side.

- Position the wishbone (3) on the swivel bearing .
- Renew screw (2) and nut (1).

**Parts:** Bolt, nut

- Insert screw (2).
- Position nut (1).
- Tighten down screw (2).

#### Wishbone to swivel bearing

M10	Exclusively use the screw to tighten! Renew screw and nut.	Tightening torque	56 Nm
-----	---	-------------------	-------

## 52 – Securing the mounted part on the front axle support

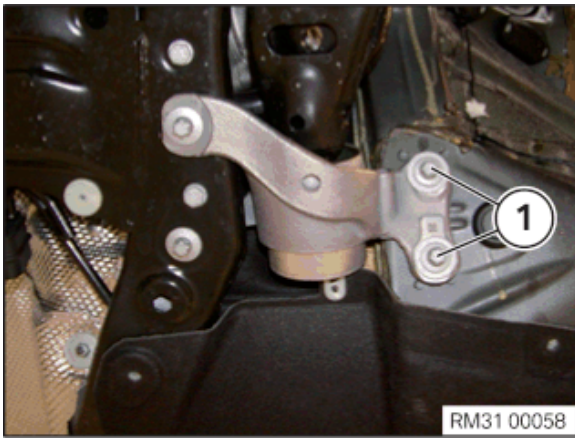

Perform the operations on the left and right side.

- Renew screws (1).

**Parts:** Screws

- Tighten the screws (1).

**Holder, wishbone rubber mount, to body**

M10 screw	Renew screw.	Jointing torque	56 Nm
		Angle of rotation	90 °

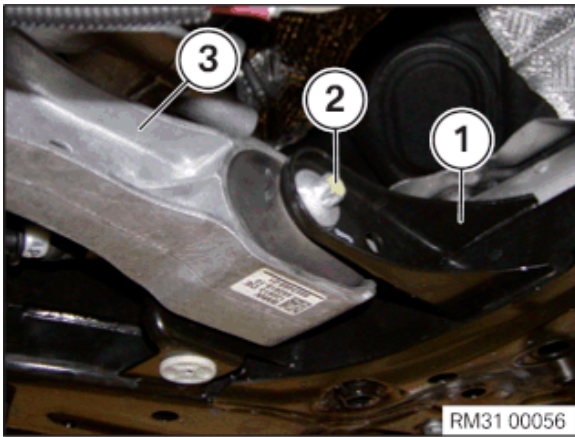

- Position the engine support (3) at the front axle support (1).
- Tighten down screw (2).

**Holder with rubber mount to front axle support**

M12 screw			100 Nm
-----------	--	--	--------

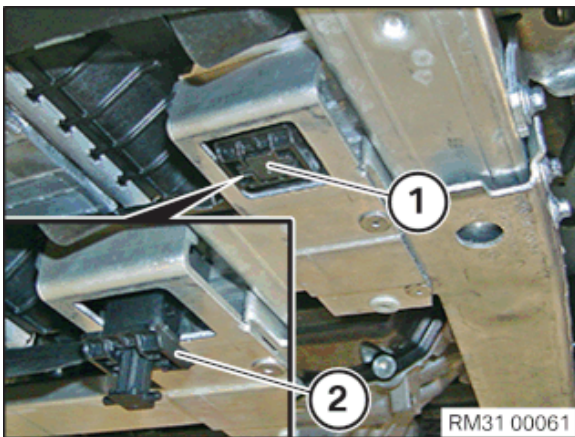

Perform the operations on the left and right side.

- Position lock (2).
- Lock safety catch (1) of the lock (2) from the holder for the charge air cooler.

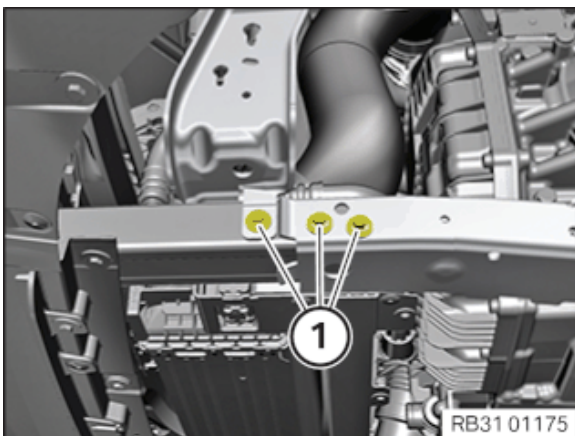

- Tighten the screws (1).

**Deformation element, bottom, to adapter plate, front axle carrier**

Screw		Tightening torque	11,8 Nm
-------	--	-------------------	---------

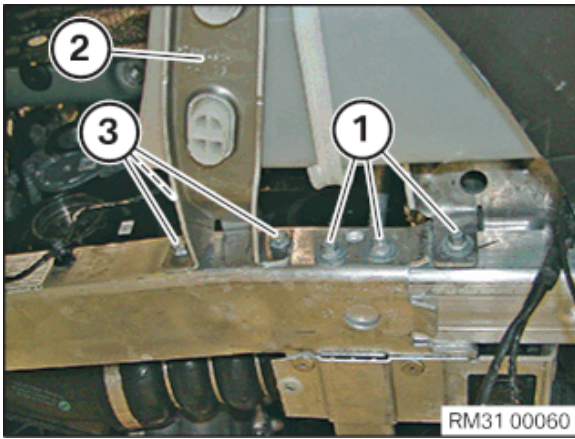

- Tighten the screws (1).

#### Deformation element, bottom, to adapter plate, front axle carrier

Screw	Tightening torque	11,8 Nm
-------	-------------------	---------

- Position the holder for the washer fluid reservoir (2).
- Tighten the screws (3).

#### Washer fluid reservoir bracket to front axle support adapter plate

Screw	Tightening torque	10 Nm
-------	-------------------	-------

### 53 – Securing the steering shaft at the bottom on the steering gear

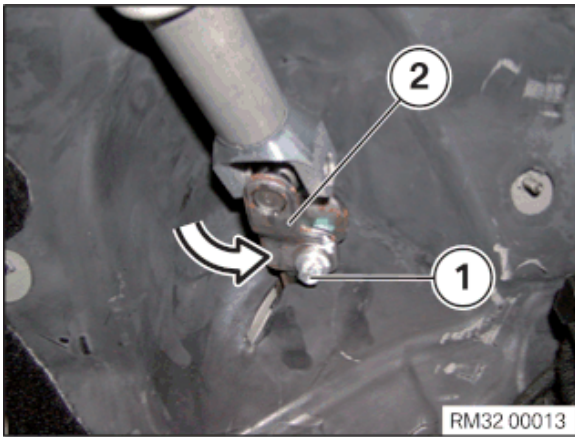

- Clean the screw thread in the universal joint (2) from the residues of screw locking agent.
- Pivot the universal joint (2) in the direction of the arrow to the steering gear.
- Renew the screw (1).

**Parts:** Screw

- Tighten down screw (1).

#### Lower steering shaft to steering gear

M10	Clean screw thread and remove remains of screw locking agent. Renew screw.	Tightening torque	28 Nm
-----	---	-------------------	-------

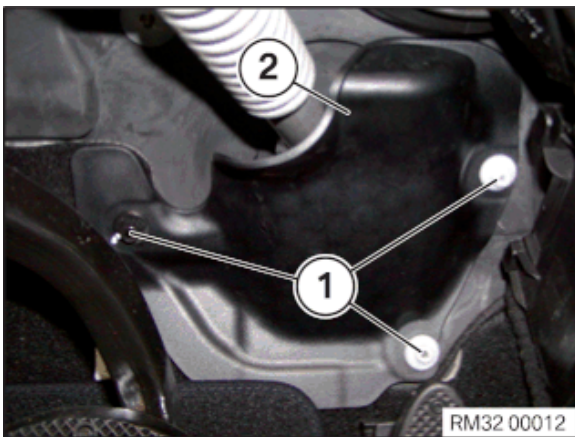

The following work step(s) is / are to be carried out if the specified component(s) is/are fitted.

- Position the cover (2) on the steering column.
- Tighten nuts (1).

#### Steering column cover to bulkhead

Plastic nut	Tightening torque	3 Nm
-------------	-------------------	------

### 54 – Attaching connector at steering gear

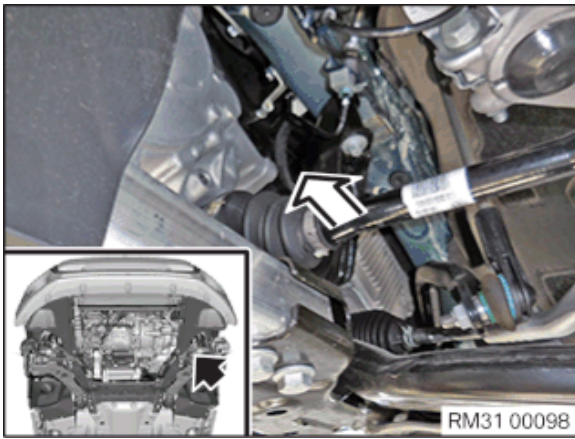

- To connect the connector (see the following step): Connect the connector with the right hand.

The connectors can be accessed via the left output shaft.

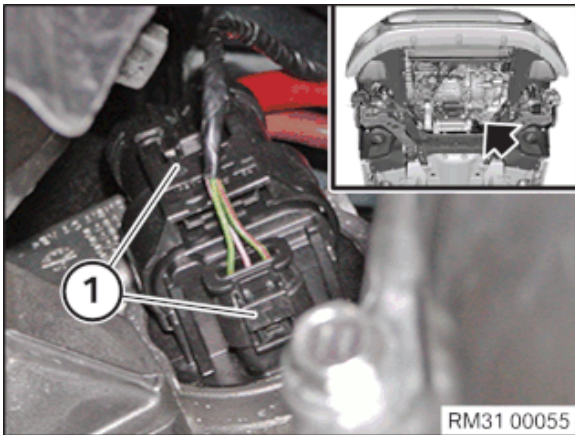

- Connect and lock connector (arrow) (1) with the steering gear.

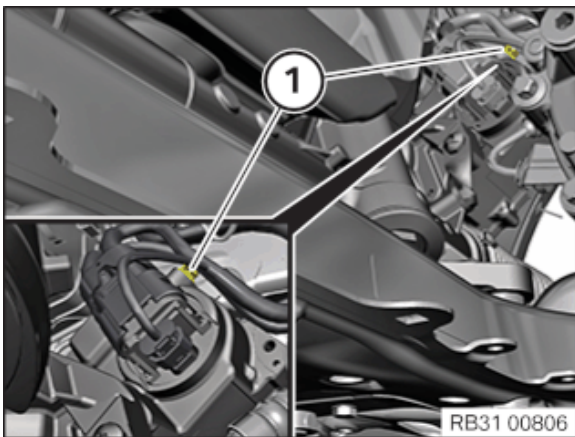

- Fasten the wiring harness (1) on the steering gear.

► **If installed: Fastening the connector with the front axle support**

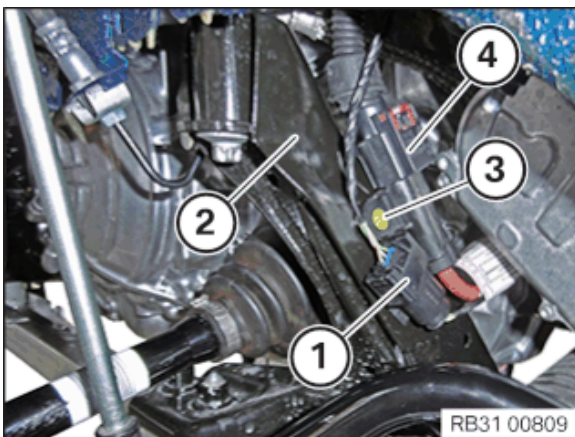

- Position the connector (4) on the front axle support (2).
- Tighten down screw (3).

**Holder to front axle support**

Oval-head screw TS5 x 16

Tightening torque

2,6 Nm

- Fasten the connector (1) on to the front axle support (2).

**55 – Securing rubber mount on front axle support**

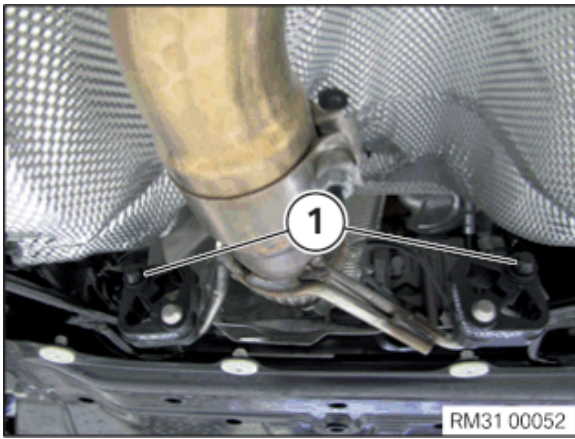

- Check the rubber mount (1) for damage and renew, if necessary.
- Spray rubber mount (1) with lubricant and slide onto holder on front axle support.

## 56 – Securing anti-roll bar on left and right on the anti-roll bar link



Perform the operations on the left and right side.

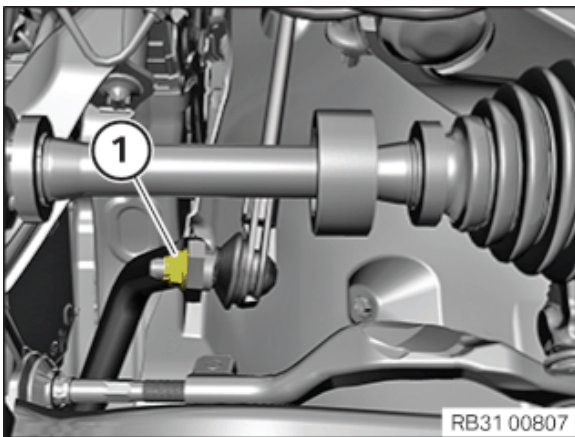

### ► Fastening anti-roll bar on the anti-roll bar link

- Position the anti-roll bar link on the anti-roll bar .
  - Renew nut (1).
- Parts:** Nut
- Tighten nut (1).

**Note:** Use the Torx socket for counter support.

### Anti-roll bar link to anti-roll bar/spring strut

M10	Renew nut.	Tightening torque	56 Nm
-----	------------	-------------------	-------

## 57 – With right installation: Securing the cable for the ride height sensor

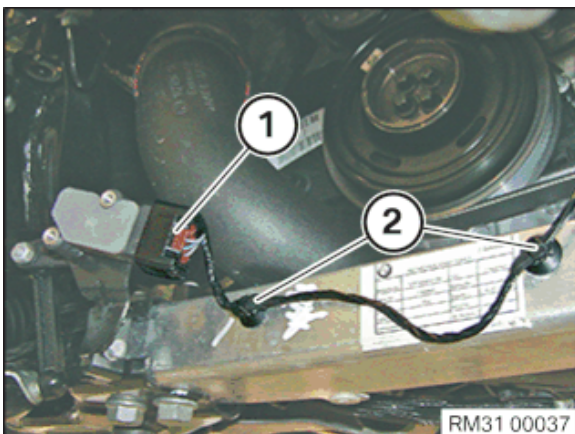

- Secure the cable clip (2) on the adapter of the deformation element.
- Connect connectors (1) and lock.

## 58 – Connecting purge air line

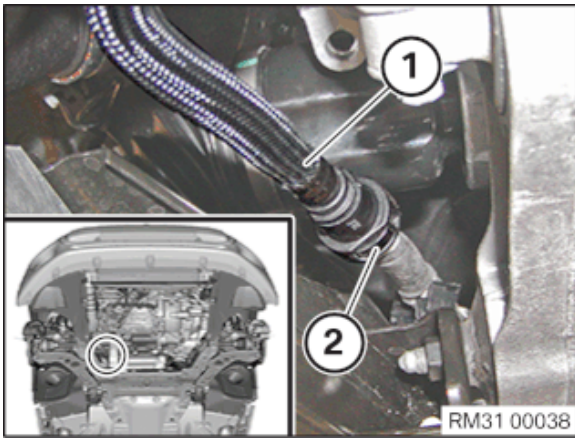

- Connect purge air line (1).
- Lock the lock (2).

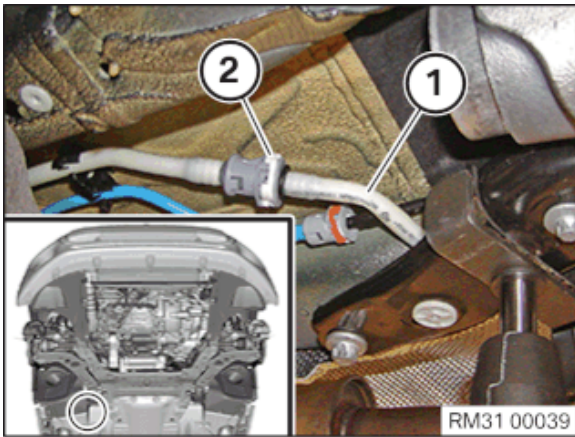

- Connect purge air line (1).
- Lock the lock (2).

## 59 – Installing starter motor



**Improper routing of the positive battery cable.**

**Risk of short circuits!**

- Route the positive battery cable without abrasions and do not trap.

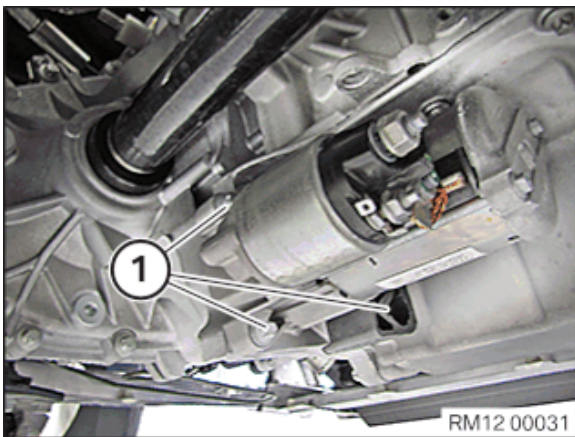

- Insert and install the starter motor .
- Tighten the screws (1).

### **Starter motor to transmission**

M8x45	Tightening torque	19 Nm
-------	-------------------	-------

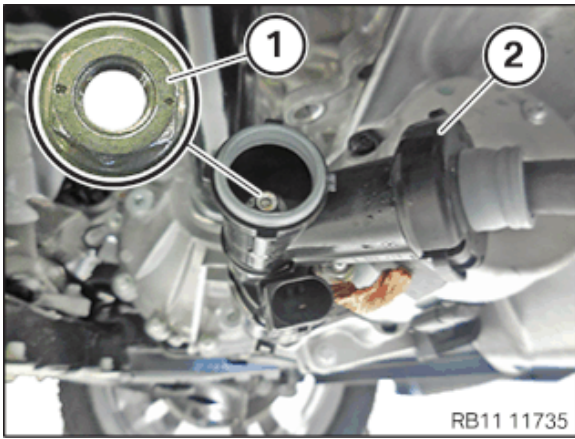

- Feed the positive battery cable (2) in on the starter and install.
- Tighten nut (1).

#### Battery positive lead to starter

M8	Tightening torque	13,5 Nm
----	-------------------	---------

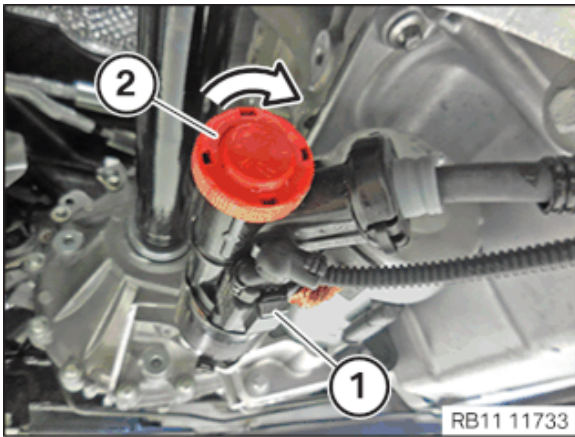

- Insert and install the new sealing cap (2).
- Secure the sealing cap (2) in the direction of the arrow.
- Connect and lock the connector (1).
- Make sure the connector (1) engages audibly.

## 60 – Top up the oil level in the manual gearbox (GS6-58BG, GS6-59DG)



**Materials harmful to health.**

**Contact with fluids harmful to health!**

- Note and follow safety information on containers.
- Conduct all work in appropriate personal protective equipment only.

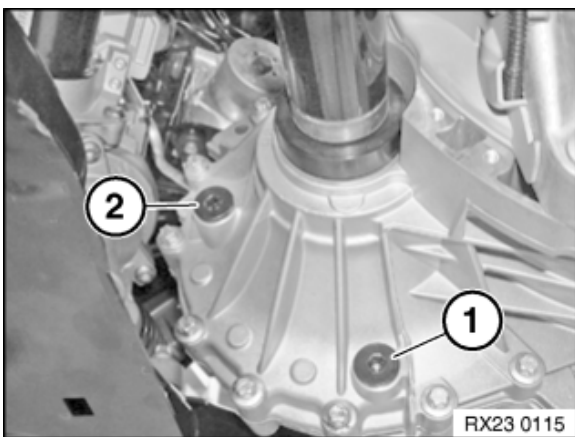

- Unscrew the oil filler plug (2) and fill the transmission, until the oil overflows.

#### Transmission oil capacity

Transmission oil GS6-58/59BG/DG	1,9 l
---------------------------------	-------

Transmission oil: Technically suitable manual gearbox oil

- Allow surplus oil to drain off.
- Replace the oil filler plug (2).

**Parts:** Oil filler plug

- Tighten the oil filler plug (2).

#### Oil drain plug / oil filler plug

Tightening torque	43 Nm
-------------------	-------

## 61 – Installing the front right wheel arch cover



Description is for left component only. Procedure on the right side is identical.

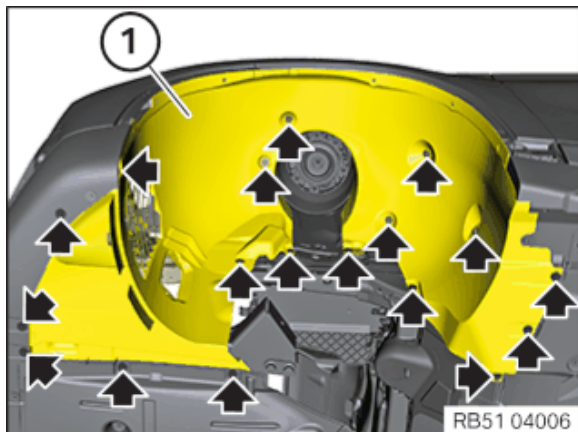

- Guide the wheel arch cover (1) in.
- Tighten all bolts and nuts (arrows).

### Wheel arch cover to body

Screw	Tightening torque	2,5 Nm
-------	-------------------	--------

### Wheel arch cover to body

Plastic nut	Tightening torque	3 Nm
-------------	-------------------	------

## ► Installing front wheel arch trim



To provide a better overview: Schematic diagram with partially hidden components.



Description is for left component only. Procedure on the right side is identical.

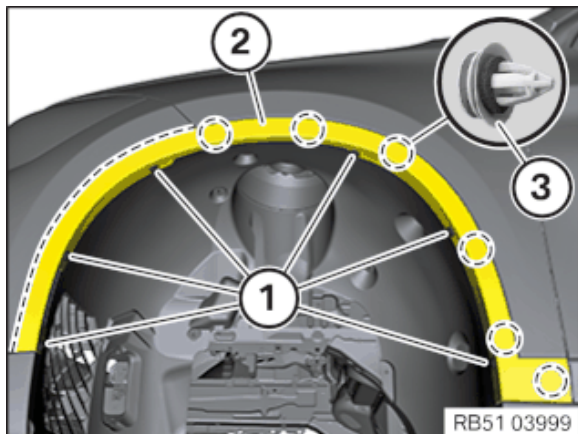

- Check the clips (3) for damage and renew where required.  
The clips (3) must not be damaged or missing.
- Feed in wheel arch trim (2) and engage on the clips (3).
- Engage wheel arch trim (2) into the latch mechanisms on the bumper panel.
- Mount blind rivet (1) using the special tool **0 496 521 (00 2 230)**.

## 62 – Mounting the front left and right wheels



Perform the operations on the left and right side.

## ► Mounting the wheel

▷ **Clean the contact surfaces between the brake disc and the wheel rim**



The contact surface between the brake disc and the wheel rim must be clean and free from oil and grease. There is otherwise a risk of the wheel becoming loose at a later time.

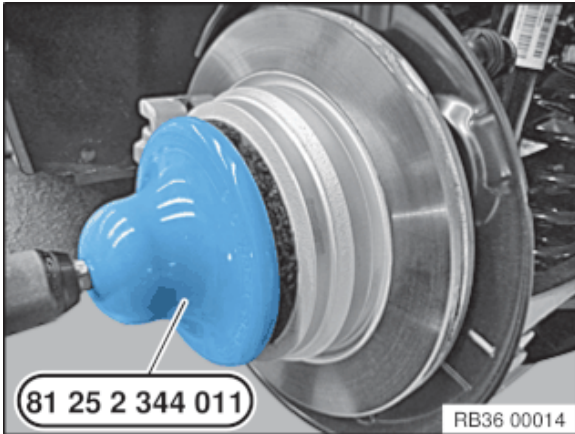

- Remove dirt, grease residues and corrosion from the contact surface with a drill and the special tool **2 344 011**.

Do not operate special tool **2 344 011** with an impact screwdriver.

- Degrease the contact surfaces with the universal cleaner (see BMW Group Parts).
- If there are grease deposits in the area of the wheel bolt holes, remove and clean the brake disc.
- Remove dirt, grease residues and corrosion from the contact surface with a drill and the special tool **2 344 011**.

Do not operate special tool **2 344 011** with an impact screwdriver.

- Degrease the contact surfaces with the universal cleaner (see BMW Group Parts).

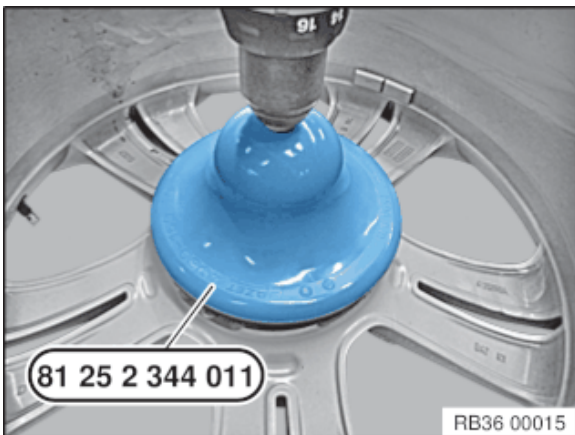

- Check that the mounting bolt (1) for the brake disc is securely seated.

The mounting bolt (1) for the brake disc **may not** protrude on the contact surface (2) between the brake disc and the wheel rim.

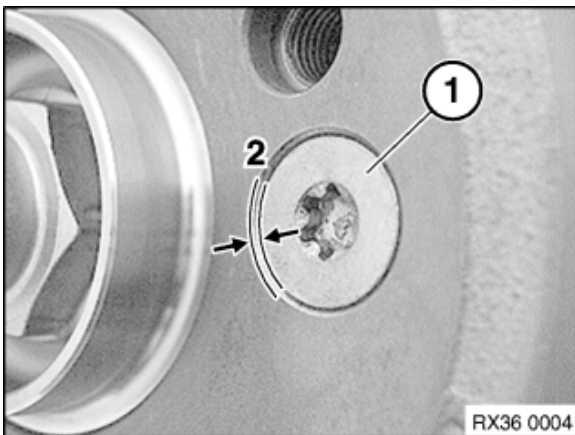

**Brake disc to front wheel hub**

M8	Tightening torque	16 Nm
----	-------------------	-------

**Brake disc to rear wheel hub**

M8	Tightening torque	16 Nm
----	-------------------	-------

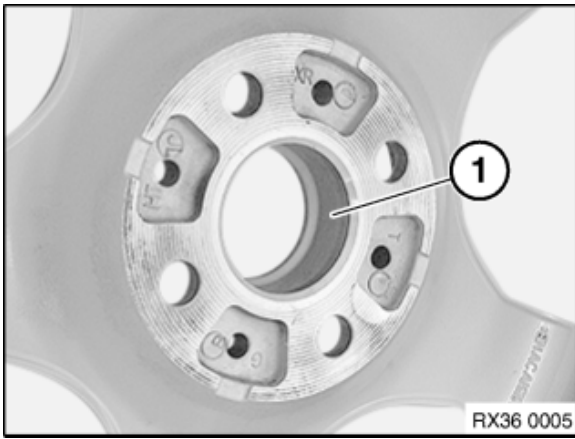

- Thinly grease the wheel centring (1) in the wheel rim.  
For the grease for the wheel centring (1) see further information.

◀

#### Check

- Check wheel bolts for wear.

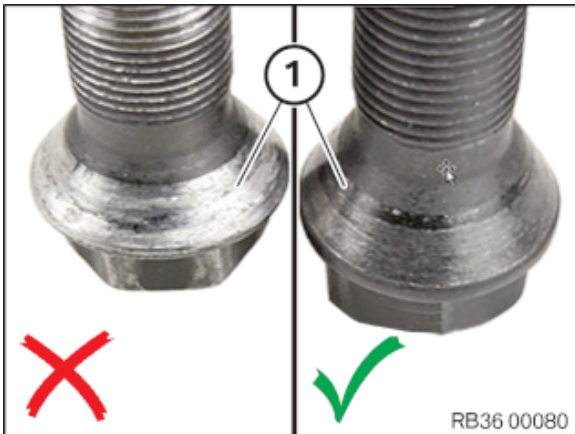

#### Result

- » Spots (> 30%) of the bearing surface (1) of the taper on the screw head show silvery wear.

#### Measure

- Replace wheel bolts.

**Parts:** Wheel bolts



Never use impact screwdrivers or electric screwdrivers to screw in and tighten the wheel bolts.

The wheel rim must rest uniformly against the brake disc.

In the case of non-original BMW wheel bolts/wheel rims, it may be necessary to retighten the wheel bolts on account of setting properties (refer to the documentation from the manufacturer).

Do not apply oil to new wheel bolts.

- Renew the corroded wheel bolts (arrows).

**Parts:** Wheel bolts

- Clean the wheel bolts (arrows).
- Check wheel bolts (arrows) and threads for damage, renew the wheel bolts if necessary.
- Join and tighten the wheel bolts (arrows).

#### Wheel bolts

M 14/AF 17	Screw in wheel bolts and evenly tighten crosswise by hand in order to centre the wheel rim.	Tightening torque	140 Nm
	Tighten wheel bolts to the prescribed tightening torque with a calibrated torque wrench in a crosswise sequence.	Check	140 Nm
	Check all the wheel bolts in the same order or retighten to the prescribed tightening torque again.		

### 63 – Removing the mounting of the coolant radiator on the left and right

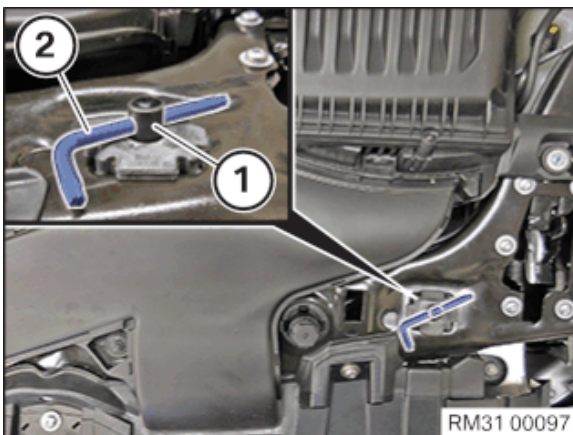

Perform the operations on the left and right side.

- Remove suitable tool (2) from the centering pin (1).

### 64 – Remove the locating pin

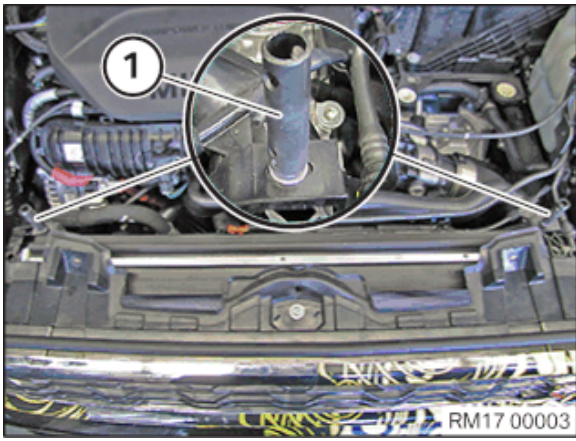

- Release locating pin (1).

### 65 – Remove cross connection

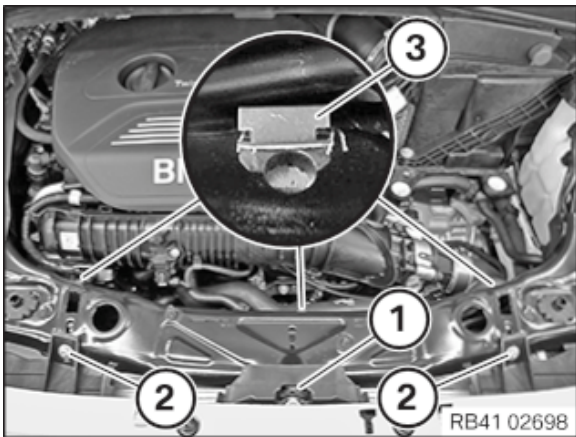

- Loosen screws (1) and (2).
- Detach clamps (3) for bonnet lock Bowden cable.

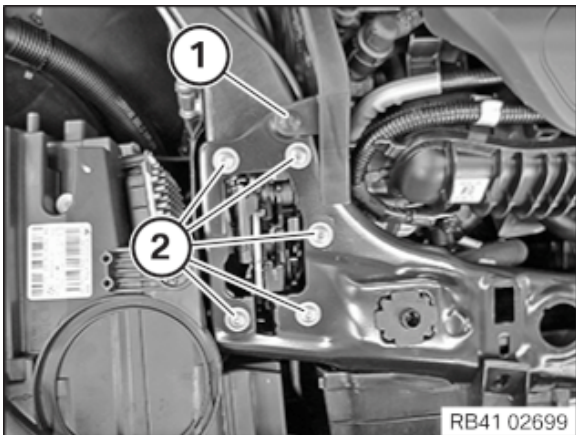

- Lever out expanding rivet (1).
- Loosen screws (2).

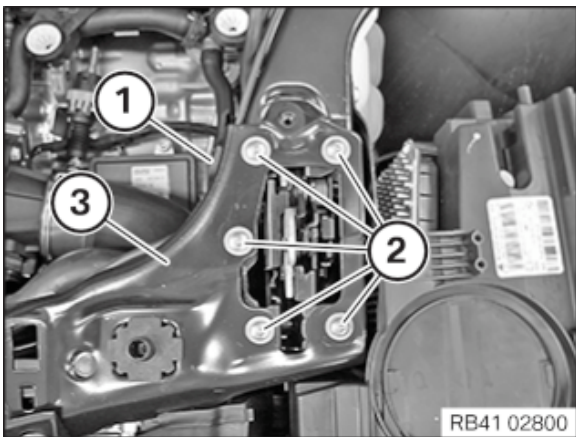

- Lever out expanding rivet (1).
- Loosen the screws (2) and remove the cross connection (3).

### 66 – Installing fan cowl with electric fan



Make sure that the connections are locked correctly. The locks must engage audibly.

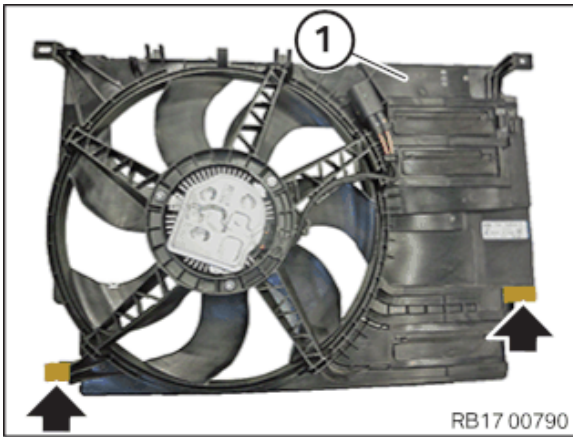

- Feed the guides (arrows) of the fan cowl (1) into the charge air cooler.

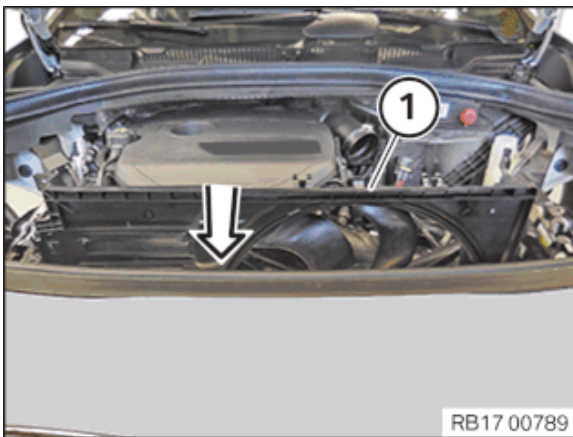

- Feed in and install the fan cowl (1) in the direction of the arrow.

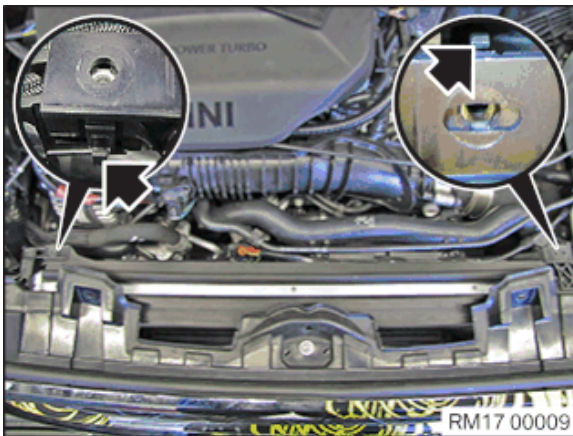

- Lock the left and right locks (arrows).

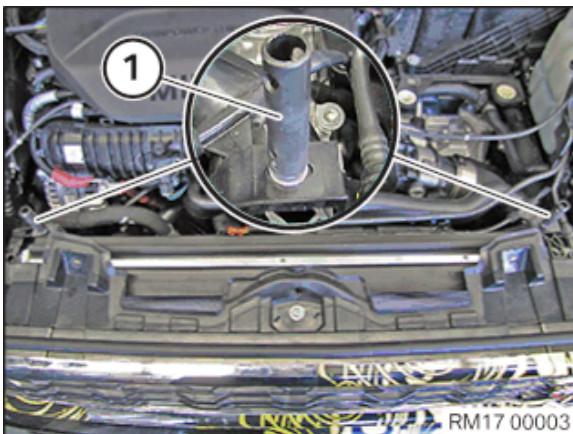

- Tighten the screws (1).

#### Fan cowl on radiator

M6X12

Tightening  
torque

6 Nm

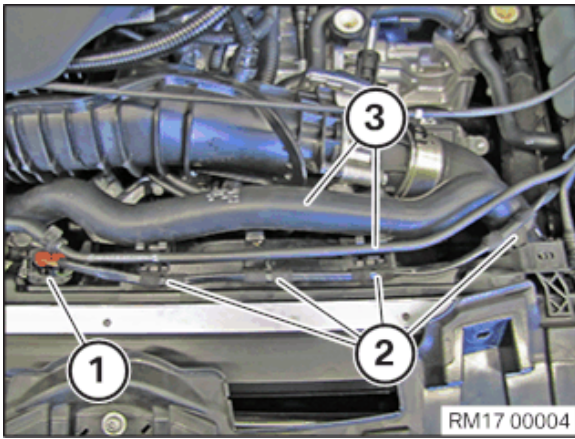

- Connect connectors (1) and lock.  
The connector (1) must engage audibly.
- Secure clamps (2).
- Thread in and install coolant line (3).

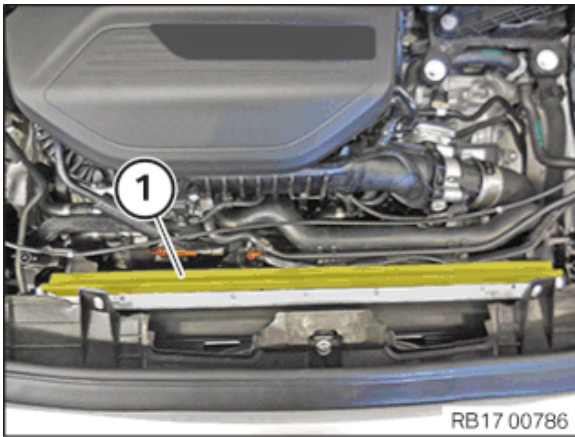

- Guide the sealing (1) on the radiator in and install it.

### 67 – Install cross connection

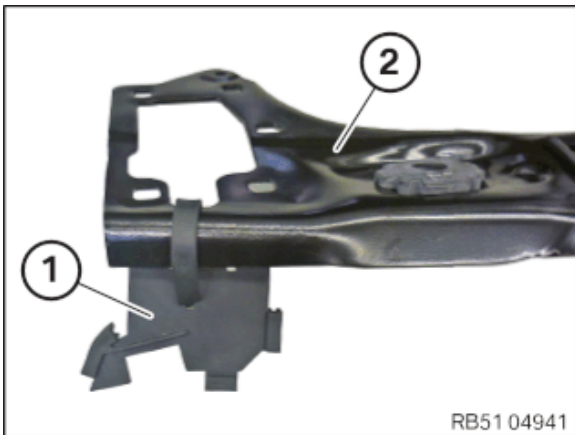

- **Installed on the right side only on vehicles with production date as of: 12/2016**
- Secure spray guard (1) to cross connection (2) as shown.

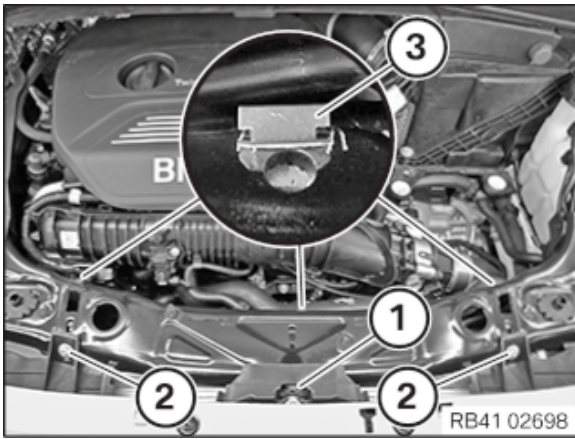

- Install cross connection.
- Position all screws.
- Tighten down screw (1).

#### Bracing strut to top cross connection

M8	Tightening torque	25 Nm
----	-------------------	-------

- Tighten the screws (2).

#### Air duct to deformation element/cross connection

M6x20 screw	Tightening torque	6 Nm
-------------	-------------------	------



**Incorrect routing of the Bowden cable for the bonnet lock.**

**Abrasion of the coolant ventilation line, coolant loss and engine overheating.**

- Route the Bowden cable of the bonnet lock correctly under the lock bridge.
- Hook the Bowden cable to all the clips.
- Make sure that the Bowden cable has no contact with the coolant ventilation line.

- Fasten clamps (3) for bonnet lock Bowden cable to cross connection.

- Tighten screws (2) of cross connection (3).

#### Cross connection on support for cross connection

M6x20	Tightening torque	12 Nm
-------	-------------------	-------

- Fasten expanding rivet (1).

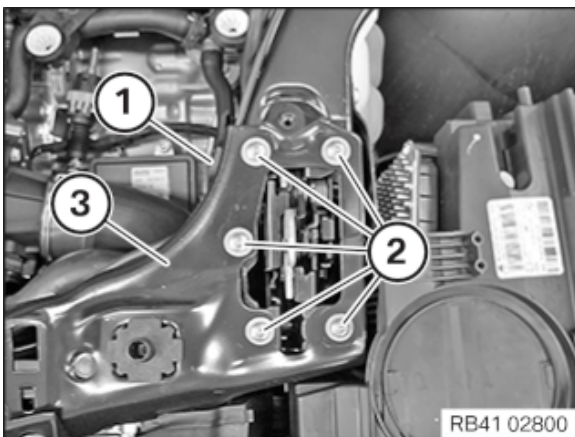

- Tighten the screws (2).

#### Cross connection on support for cross connection

M6x20	Tightening torque	12 Nm
-------	-------------------	-------

- Fasten expanding rivet (1).

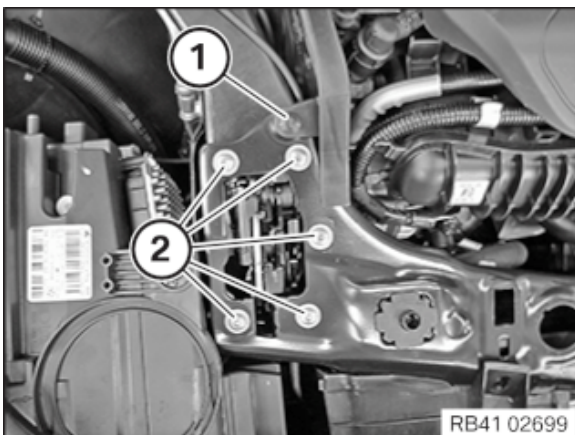

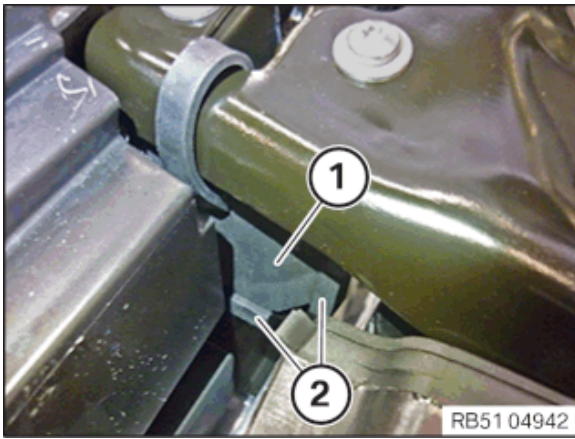

- **Installed on the right side only on vehicles with production date as of: 12/2016**
- Mount spray guard (1) correctly to prevent corrosion.
- Secure spray guard (1) to the lock bridge with retaining tabs (2).

## 68 – Topping up the engine oil



### **Damage to the petrol particulate filter.**

**Vehicles equipped with a petrol particulate filter must be operated using low-ash engine oil only.**

- Only use engine oils approved by BMW for the respective engine.
- For additional information see: Summary of technically suitable engine oils for BMW Group engines.



### **Engine damage caused by excessively filling the engine with engine oil.**

**Filling an excessive quantity of engine oil may cause engine damage.**

- Observe the exact engine oil filling capacity.
- Allow engine oil to drip off when draining.

- Pour in engine oil.

### **Engine oil B38A15M1/B38A15U1**

Capacity of engine oil

4.5 l

Engine oil: Technically suitable engine oils for BMW Group engines

## 69 – Installing the oil filler cap

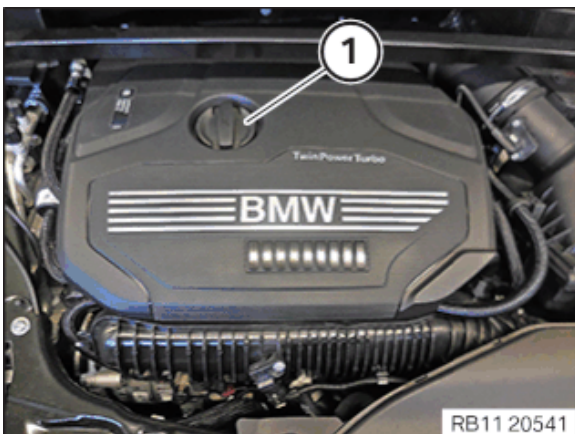

- Close oil filler cap (1).

## 70 – Filling the coolant circuit by means of the vacuum filler device

## Vacuum filler device

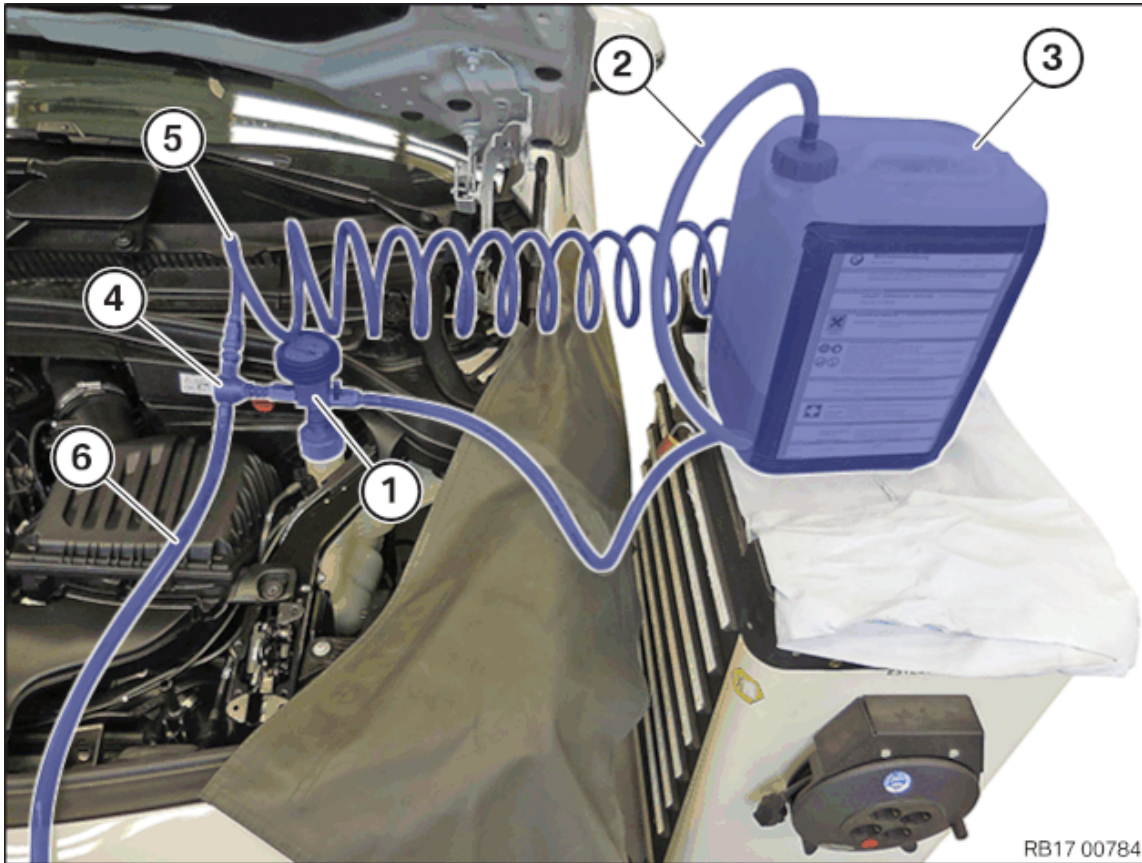

Vacuum filler device - connected to the high-temperature coolant expansion tank

- 1 Vacuum filler device with pressure gauge and shutoff valves
- 2 Filling hose
- 3 Fluid tank with coolant
- 4 Venturi nozzle
- 5 Compressed air connection (maximum 6 bar)
- 6 Out-going hose (lead out-going hose into a collecting vessel)

### Prerequisite

The coolant expansion tank for the cooling system must be empty. The fluid tank of the vacuum filler device must have a sufficient quantity of premixed coolant, 1 l to 2 l more than the specified capacity for the vehicle. The fluid tank of the vacuum filler device must be positioned at the same height as the coolant expansion tank. The compressed air connection must have a pressure of 6 bar. Ignition is switched off.



Follow notes for repair work on the cooling system.

For additional information see:

Main group 17

17 00 ... Notes for working on the cooling system



### **Life-long fill of coolant!**

Do not reuse used coolant.

When replacing and removing components which rely on the corrosion protection effect of the coolant, it is essential to change the coolant. The cooling system must therefore be emptied and refilled.

In the case of other removal work involving the draining of part quantities of coolant, the coolant level must be topped up with new coolant.



Filling **without** the vacuum filler device (watering can filling) is **not permitted**.

Non-compliance will result in danger of component and/or engine damage.

Filling specification **absolutely must** be adhered to.

Operation of the vehicle is not permitted unless the filling procedure has been completed. Otherwise, functional limitations (degradation) and/or overheating may occur.

A bleeding procedure is required after a part has been exchanged in the cooling system and/or after refilling the cooling system.



Make sure that the ignition (terminal 15) is switched off prior to creating the vacuum with the vacuum filler device.

► **Observe the coolant type**

## Coolant in the collecting vessel of vacuum filler device

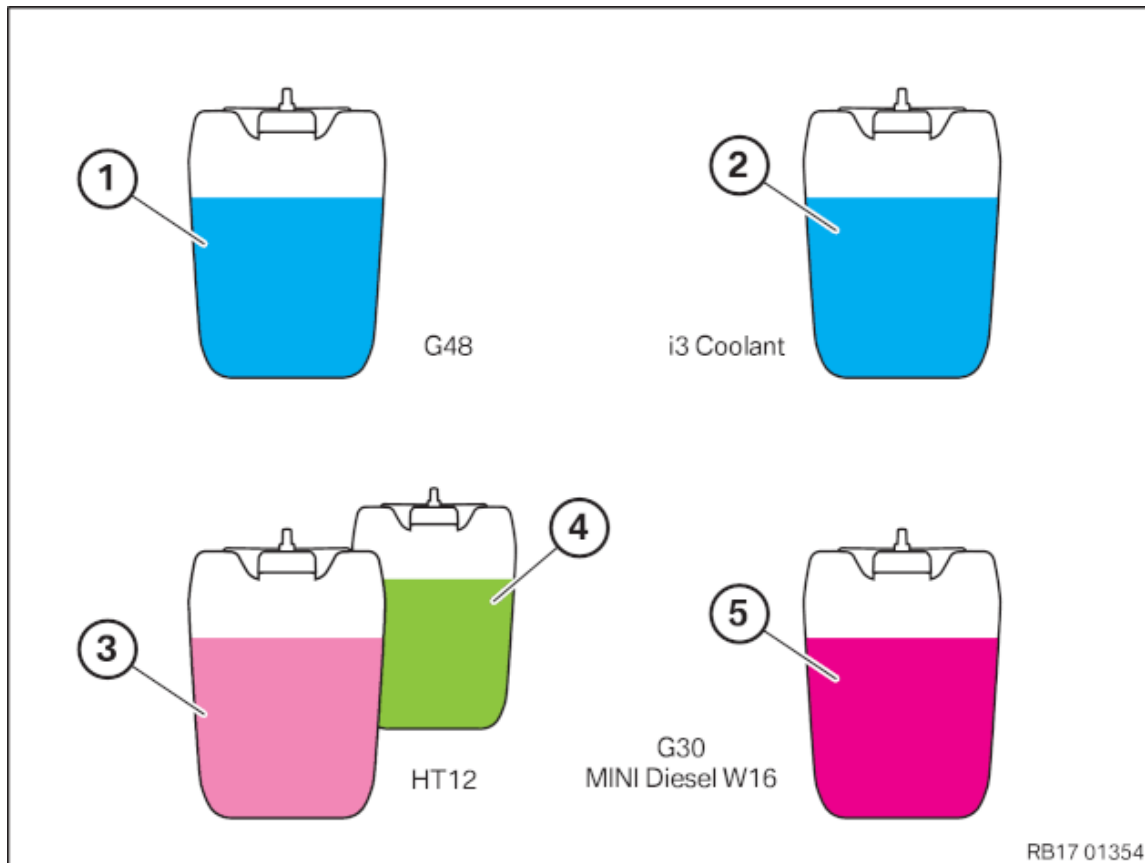

Choose the correct coolant for filling.

In general, a vehicle has to be filled with the coolant with which it is delivered from the factory.

- 1 G48 (Blue) (BMW LC-87)** Must **not** be mixed with i3 Coolant or G30 MINI Diesel W16.
- 2 i3 Coolant (Blue) (BMW LC-13)** Is used only for heater circuit i3. i3 Coolant must **not** be added to other coolant circuits or mixed with other coolants.
- 3 HT12 (Rose) (BMW LC-18)** Must **not** be mixed with i3 Coolant or G30 MINI Diesel W16.
- 4 HT12 (Green) (BMW LC-18)** Must **not** be mixed with i3 Coolant or G30 MINI Diesel W16.
- 5 G30 (Rose) (BMW LC-07)** May be W16 used exclusively for the **MINI Diesel**. G30 must **not** be filled in the other coolant circuits or mixed with the other coolants.



### Damage to the engine or components in high-voltage vehicles

**The use of an incorrect coolant may lead to corrosion or gelling in the coolant circuit.**

- Use only approved coolants for the specific vehicle.
- Fill the vehicle only with the coolant with which it was delivered ex works.
- Mix only compatible coolants. The colour does not allow any assessment about the compatibility of coolants.
- Selection of the correct coolant only by means of the part number.

- Select a suitable adapter (Y) from the set of special tools **0 494 417 (17 0 100)**:

Type	Engine	Adapter (Y) from 17 0 100
F39/F40/F45/F46/F48/F52	B46/B48/B38/B47/B37	17 0 109

- The fluid tank of the vacuum filler device must be filled with 1 l to 2 l more than the specified capacity of coolant for the vehicle.

### Coolant filling quantity in the cooling system

B38A15M1, B38A15U1, B36A15M1 with manual gearbox without auxiliary radiator	6,75 l
B38A15M1, B38A15U1, B36A15M1 with manual gearbox with auxiliary radiator	7,45 l
B38A15M1, B38A15U1, B36A15M1 with automatic transmission without auxiliary radiator	7,0 l
B38A15M1, B38A15U1, B36A15M1 with automatic transmission with auxiliary radiator	7,7 l
B38A15M1, B38A15U1, B36A15M1 with double-clutch transmission without auxiliary radiator	7,1 l
B38A15M1, B38A15U1, B36A15M1 with double-clutch transmission with auxiliary radiator	7,8 l

Expendable materials: Technically suitable antifreeze and corrosion inhibitor

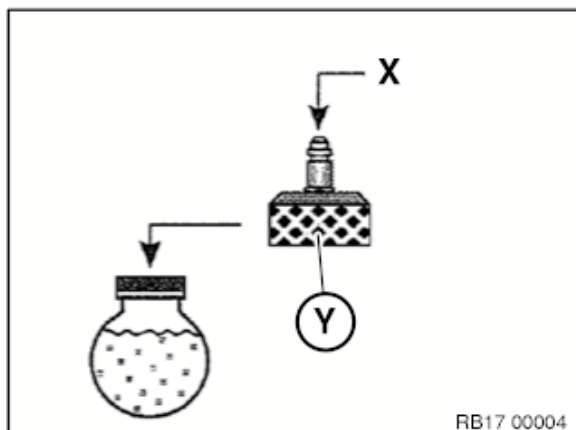

- Connect the selected adapter (Y) to the coolant expansion tank.
- Connect vacuum filler device to connection (X) of the adapter.

RB17 00004

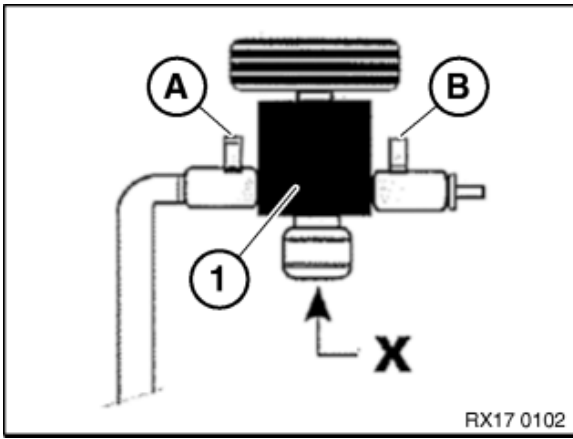

- Make sure that the shutoff valves (A) and (B) of the vacuum filler device (1) are closed.
- Connect and lock connection (X) to the coolant expansion tank.

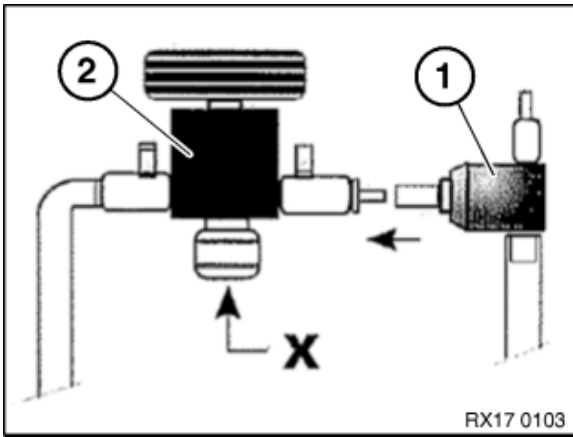

- Connect Venturi nozzle (1) to the vacuum filler device (2). (X) is the connection on the coolant expansion tank.

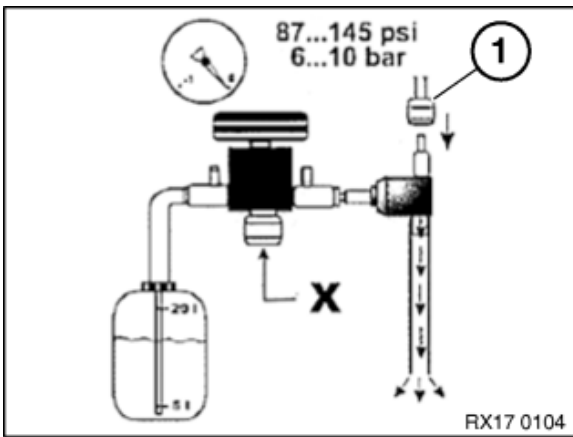

- Connect compressed air (1). (X) is the connection to the coolant expansion tank.

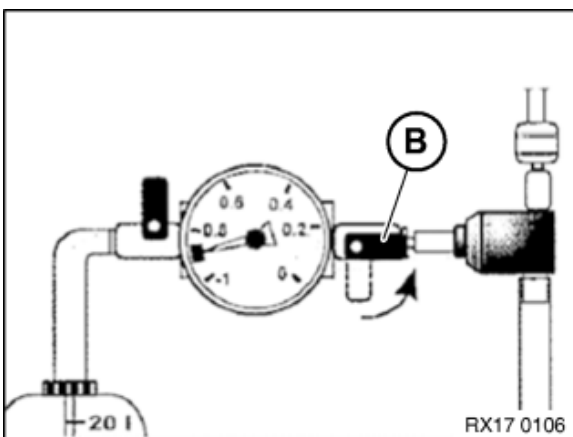

- Open shut-off valve (B). The Venturi nozzle produces a flow noise.

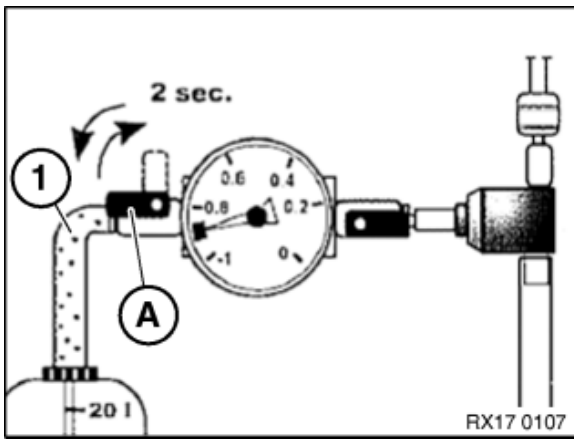

- Open shutoff valve (A) until the fuel filling hose (1) is full without bubbles.
  - Close shutoff valve (A) again.
- » The filling hose (1) has now been bled.

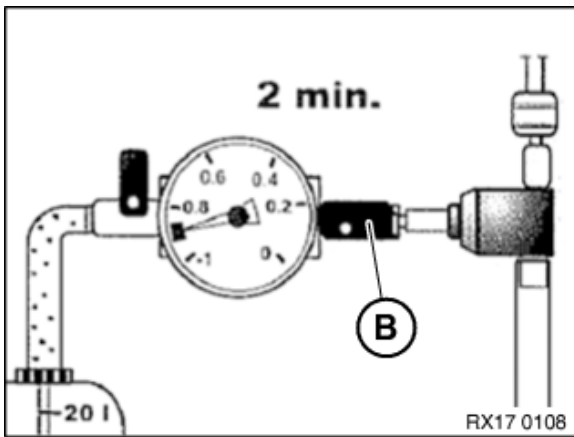

- Check the coolant hoses for porosity and renew porous coolant hoses as required.



The coolant hoses contract during vacuum build-up.

- After a vacuum of -0.7 to -0.95 bar has been reached in the coolant circuit (duration approximately 2 minutes), close the shutoff valve (B).

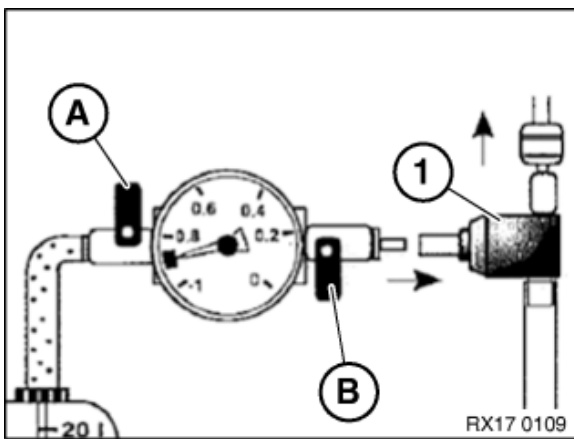

- Check whether the shut-off valves (A) and (B) are closed.
- Disconnect the Venturi nozzle (1).

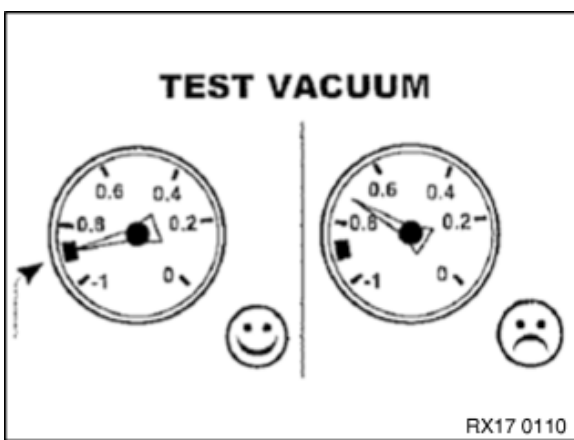

#### Check

- The vacuum in the coolant circuit must be maintained for at least 30 seconds.

#### Result

» Vacuum drops.

#### Measure

- Look for the leak, repair it and start the filling procedure from the beginning.

#### Check

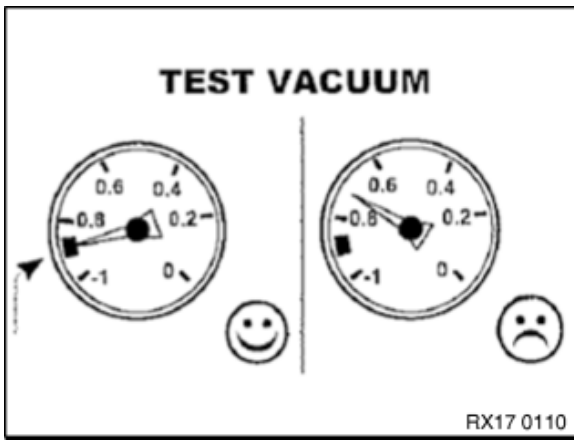

- The vacuum in the coolant circuit must be maintained for at least 30 seconds.

#### Result

» Vacuum remains constant.

#### Measure

- Continue with filling.
- Keep shutoff valve (B) closed during the filling process.
- To fill the cooling system, open the shutoff valve (A) to the fluid tank of the vacuum filler device.

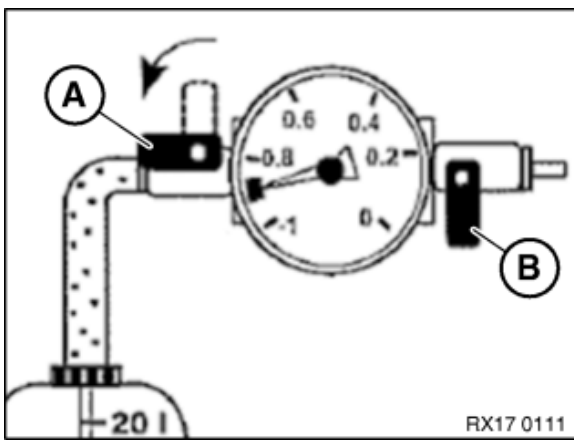

- Stop the filling procedure when the needle in the pressure measuring device is on 0 bar or it no longer drops.
- If necessary, reduce remaining vacuum. In order to do so, open shutoff valve (B).

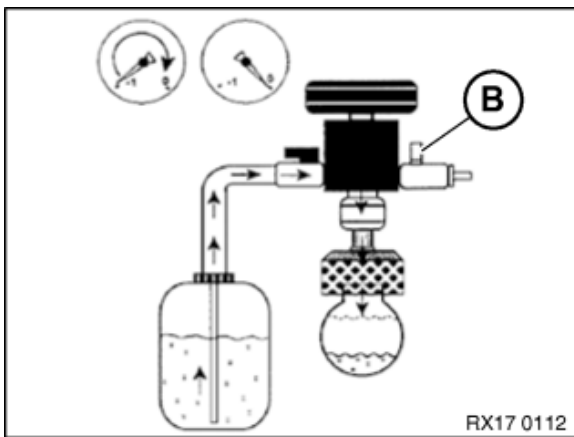

- Remove the vacuum filler device with the adapter from the coolant expansion tank.
- Adjust the coolant level to 700 ml above the maximum mark.
- After filling the cooling system with the vacuum filler device perform the cooling system bleeding routine additionally.

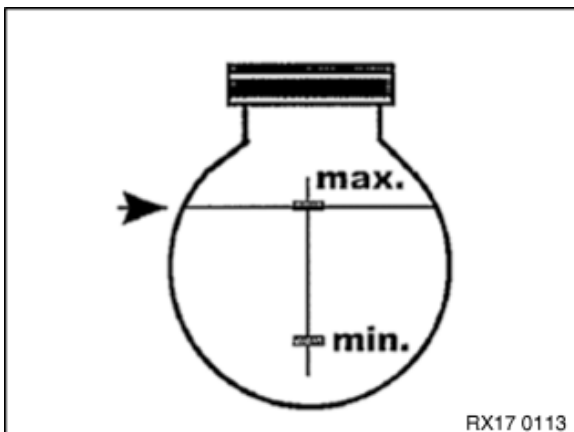

## Prerequisite

The engine is switched off.

Heating and air conditioning system is switched off.

The refrigerant circuit is evacuated and tight.

Vehicle must be positioned on the ground.



### Refrigerant circuit under high pressure.

#### Danger of injury!

- Note and follow safety information on containers.
- Avoid contact with refrigerant; wear safety goggles and protective gloves.
- For additional information see: 64 50 Handling refrigerant and 6450 Notes on air conditioning repair work



Filling a raised vehicle will result in insufficient filling levels.



In some cases, Sanden SP-A2 refrigerant oil must be injected into the refrigerant circuit. See further information.

- Determine the quantities of **new** refrigerant oil to be refilled:

**In addition** to the drawn off and recorded amount of refrigerant oil, add the following quantities (if applicable):

- *Top up the refrigerant oil losses over time as per the table:*

**Table 1** indicates the permitted loss of refrigerant after a specific period of time. There is **no** leak. Refrigerant oil must **not** be topped up.

**Table 2** indicates the amount of refrigerant oil which must be **topped up** after a specific period of time with an **impermissible** loss of refrigerant due to a leak.

**Case 1:** Refrigerant loss is **not exceeded** as per Table 1:

- Top up missing refrigerant
- It is **not permitted** to top up the refrigerant oil

**Case 2:** Refrigerant loss is **exceeded** as per Table 1:

- Top up missing refrigerant
- Refrigerant oil must be **topped up additionally** as per Table 2

<b>Table 1/case 1</b>					
Number of years since last filling	0-1	1-2	2-3	3-4	4-5
Permissible loss [g] --> <b>Do not top up refrigerant oil</b>	≤ 30	≤ 60	≤ 90	≤ 120	≤ 150

<b>Table 2/case 2</b>		
Number of years since last filling	Loss of refrigerant [g]	Top up quantity refrigerant oil
0-1	< 120	0
0-1	120-150	10
0-1	> 150	20
1-2	< 180	0
1-2	180-210	10
1-2	> 210	20
2-3	< 240	0
2-3	240-270	10
2-3	> 270	20
3-4	< 300	0
3-4	300-330	10
3-4	> 330	20
4-5	< 360	10
4-5	> 360	20

- *Add refrigerant oil as per the table if parts of the refrigerant circuit have been replaced:*

**Case 1:** Part exchange as preliminary work for additional work and part exchange due to **slow leakage** (minor leak, e.g. hairline crack)

**Case 2:** Part exchange due to **sudden leakage** (major leak, e.g. line disconnection caused by accident)

	<b>Case 1</b>	<b>Case 2</b>
Air conditioning compressor*	*	*
Evaporator	10 ml	35 ml
Air conditioning condenser without integrated desiccant insert	20 ml	35 ml
Air conditioning condenser with integrated desiccant insert	40 ml	55 ml
Desiccant insert/dryer flask	20 ml	55 ml
Per replaced refrigerant line	10 ml	35 ml
Safety pressure switch, gaskets	0 ml	0 ml

\*Air conditioning compressor: see 6452 lubricating the air conditioning compressor

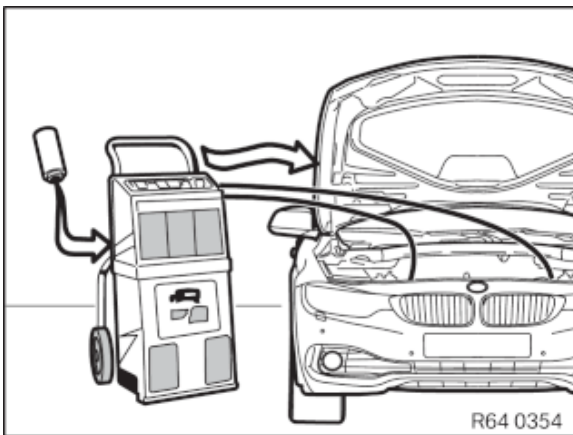

- Top up determined amount of refrigerant oil into the refrigerant circuit.
- Fill the amount of refrigerant as per the type plate into the refrigerant circuit.
- Disconnect the high pressure line and low pressure line on the vehicle.
- Drain the high pressure line and low pressure line.
- Once again close the refrigerant filler neck on the vehicle with the sealing caps.

## 72 – Install electronics box

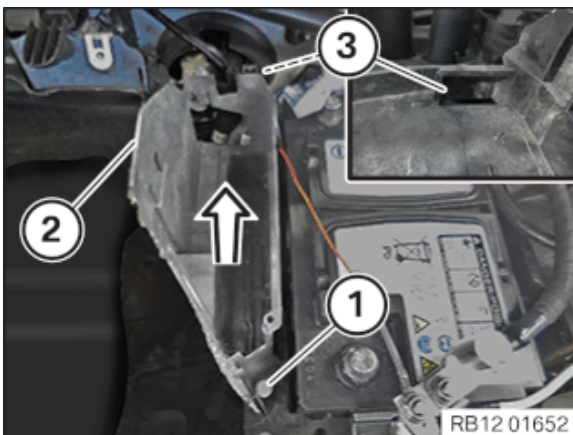

- Guide the electronics box (2) into the guide (3) in the direction of arrow and install.
- Tighten down screw (1).

### Electronics box to battery tray

M8X16

Tightening  
torque

15 Nm

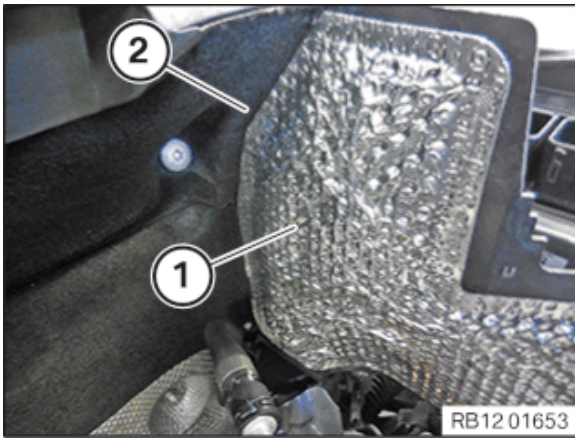

- Make sure the electronics box (1) is positioned correctly on the bulkhead (2).

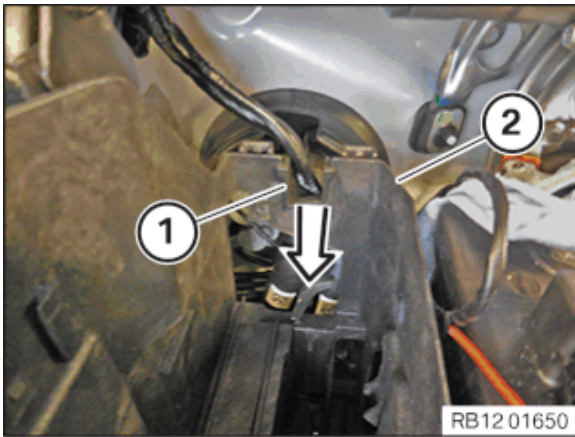

- Insert the holder (1) at the electronics box (2) in the direction of the arrow and install.
- Make sure the bracket (1) engages audibly.

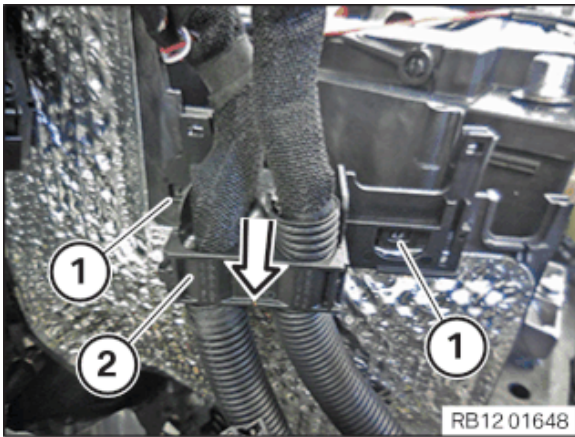

- Feed in the wiring harness section (2) of the engine in the direction of the arrow and install.
- Ensure that the locks (1) engage audibly.

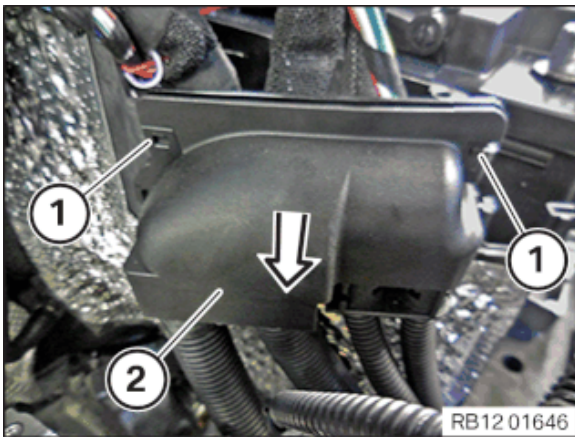

- Thread in and install the wiring harness section (2) for the Valvetronic servomotor in direction of arrow.
- Ensure that the locks (1) engage audibly.

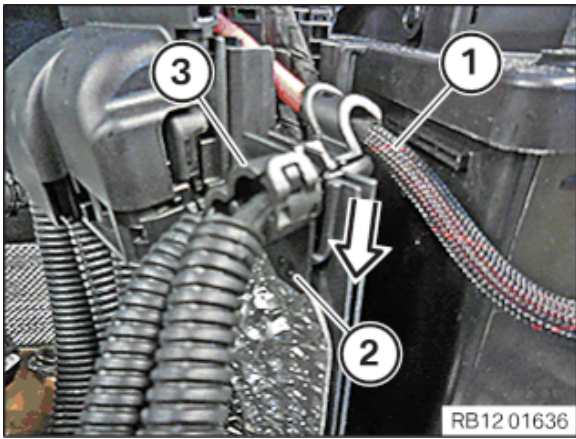

- Insert and install the wiring harness section (3) for the injectors and ignition coils in direction of arrow.
- Ensure that the lock (2) engages audibly.
- Insert and install the positive battery cable (1).

## 73 – Installing the integrated supply module (PDM)



### Improper routing of cables and wiring harnesses.

Trapped, crushed or damaged cables may cause short circuits and malfunctions.

- Route all cables without abrasions, do not trap and crush.

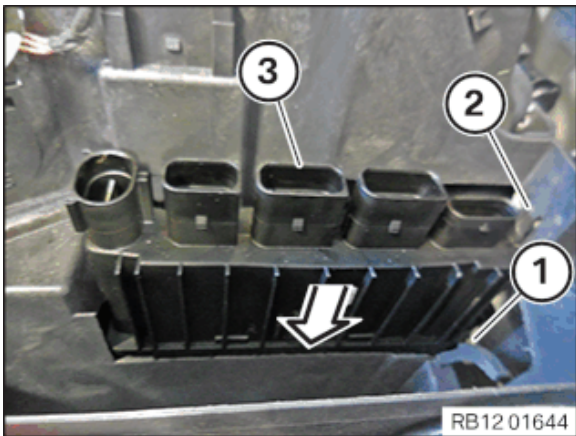

- Insert and install the integrated supply module (3) in the direction of the arrow.
- Make sure you can hear the locks (1) and (2) engage.

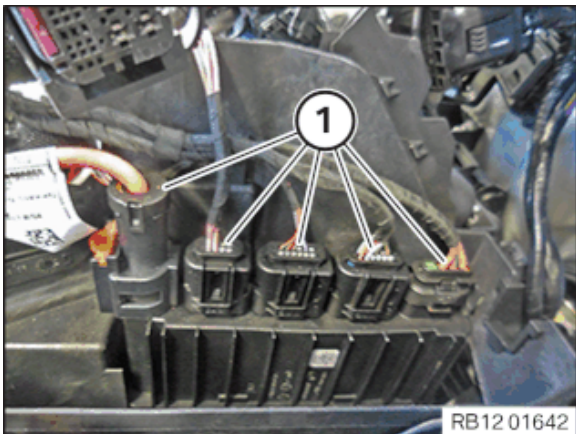

- Connect connectors (1) and lock.
- Make sure the connectors (1) engage audibly.

## 74 – Installing the DME control unit

### Prerequisite

Disconnect battery.



### Improper routing of cables and wiring harnesses.

**Trapped, crushed or damaged cables may cause short circuits and malfunctions.**

- Route all cables without abrasions, do not trap and crush.



In a warranty case, you must always provide a fault memory printout with the defective part, even if the fault memory does not contain an entry.



Control unit must be programmed after it is replaced.

For additional information see: 61 00 ... Programming/encoding control unit(s)

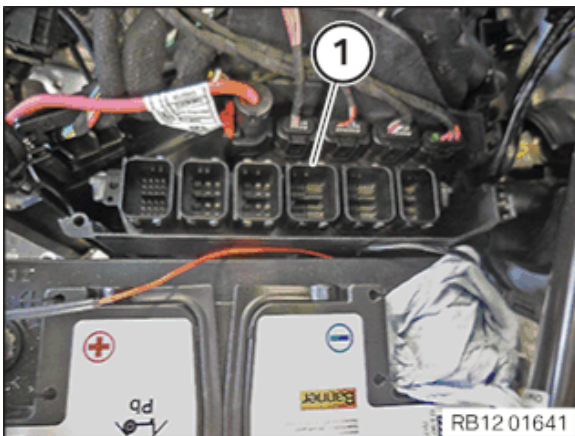

- Feed in and install DME control unit (1).

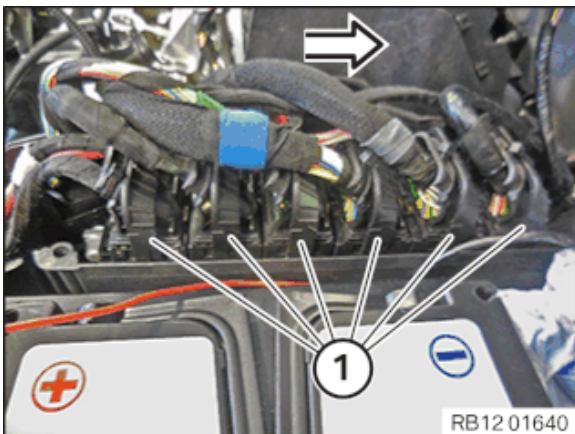

- Connect connector (1) in direction of arrow and lock.
- Make sure the connectors (1) engage audibly.

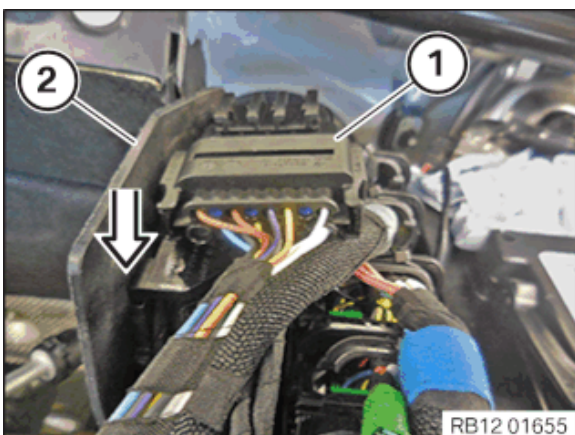

- Connect and lock the connector (1).
- Make sure the connector (1) engages audibly.
- Insert the connector (1) in the direction of arrow at the electronics box (2) and install.

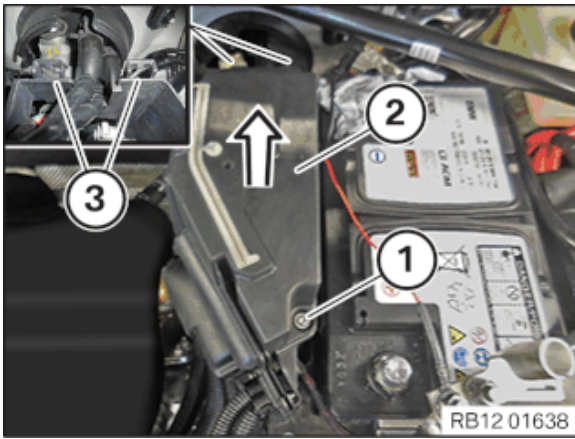

- Insert the cover (2) into the guides (3) in the direction of arrow and install.
- Make sure the cover audibly engages (2) in the guides (3).
- Tighten down screw (1).

#### Cover to electronics box

RF5x26.5	Tightening torque	2,5 Nm
----------	-------------------	--------

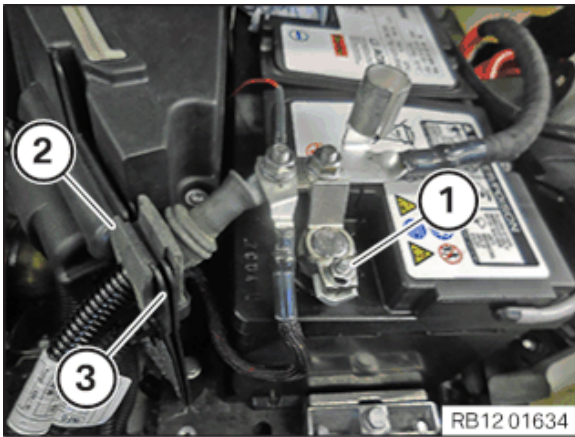

- Thread in positive battery cable (2) on holder (3) and install.
- Feed in and install positive battery terminal (1).
- Tighten positive battery terminal (1).

#### Positive battery terminal to battery

NutM6	Tightening torque	5 Nm
-------	-------------------	------

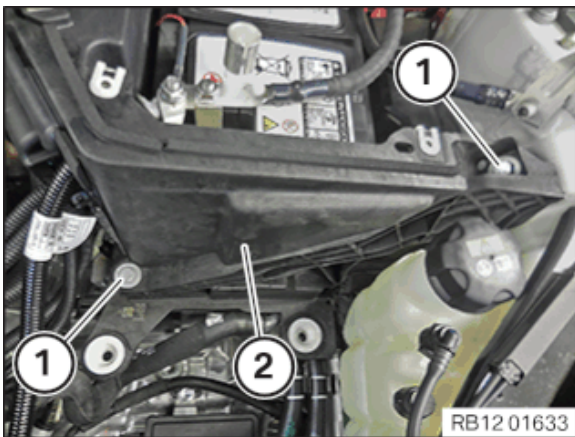

- Feed in and install tension strut (2).
- Tighten the screws (1).

#### Tension strut to spring strut dome/battery tray

M8	Tightening torque	19 Nm
----	-------------------	-------

## 75 – Installing system battery

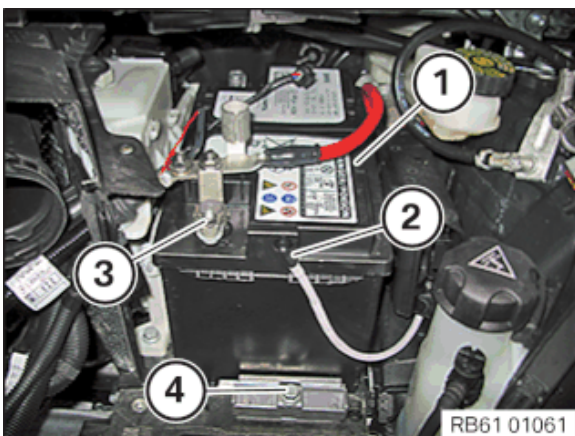

- Install system battery (1).
- Position the bracket and tighten with the screw (4) .

#### Battery terminal rail to battery tray

M8		19 Nm
----	--	-------

- Position the vent hose (2) and clip it in.
- Position the positive battery terminal and tighten with the nut (3) .

#### Battery terminal with IBS positive battery terminal / negative battery terminal

NutM6		5 Nm
-------	--	------

► Check the vent holes of the battery



### Gas emission.

#### Danger of injury! Danger of explosion!

- Assign the vent holes correctly.
- Route the vent hose correctly.



The battery has two vent holes, opposite:

One vent hole (1) must be closed correctly with a dummy plug.

The vent hose (3) must be correctly connected and routed at the other vent hole (2).

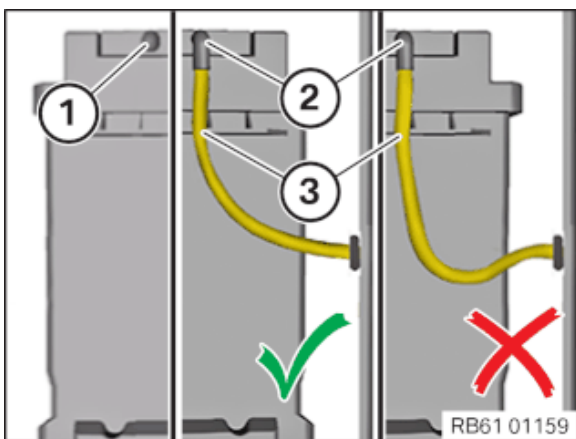

#### Check

- Check if the vent hole (1) is correctly closed with a dummy plug.

#### Result

» No dummy plug.

#### Measure

- Close the vent hole (1) correctly with a dummy plug.

#### Check

- Check whether the vent hose (3) at the vent hole (2) has been connected correctly.

#### Result

» The vent hose (3) is not correctly connected.

#### Measure

- Connect the vent hose (3) with the vent hole (2) correctly.

#### Check

- Check whether the vent hose (3) is routed with a downhill gradient to the outside (**no siphon formation**).

#### Result

» The vent hose (3) is not routed correctly as shown at the right.

#### Measure

- Route the vent hose (3) correctly as shown in the centre.

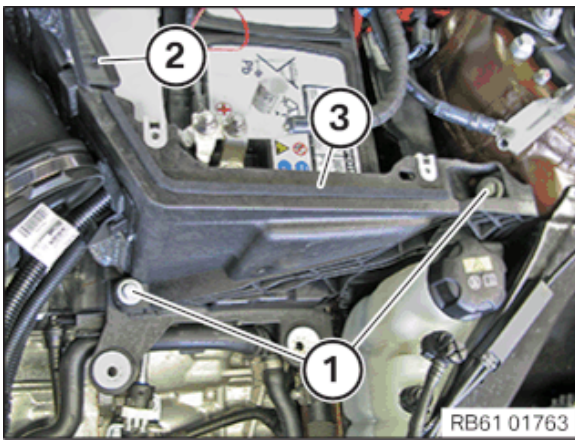

- Insert tension strut (3) and tighten with screws (1).

#### Trailing link

M8	Tightening torque	19 Nm
----	-------------------	-------

- Tighten down screw (2).

#### Battery cover

M8		2,8 Nm
----	--	--------

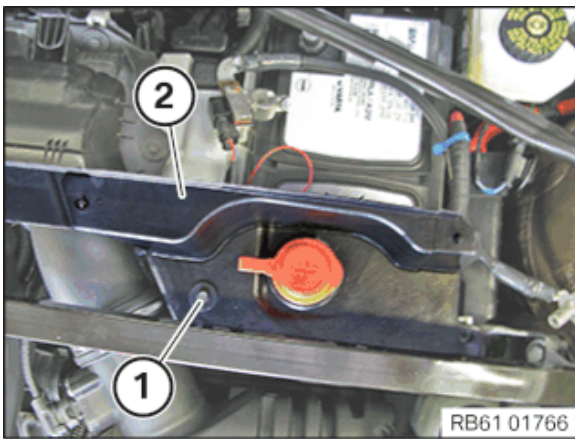

- Position the cover (2).
- Tighten down screw (1).

#### Battery cover

M8		2,8 Nm
----	--	--------

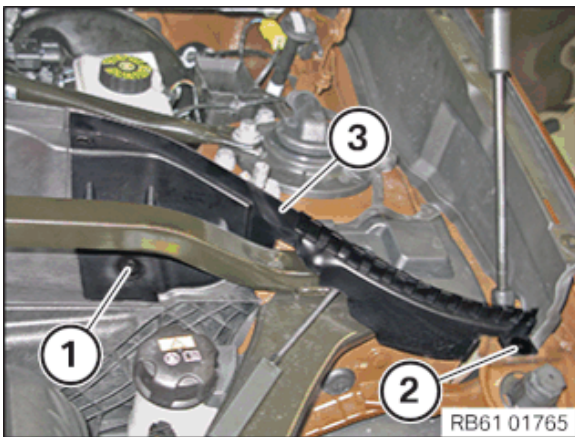

- Position the fixture for the gasket (3) and secure with the expanding rivet (2).
- Tighten down screw (1).

#### Battery cover

M8		2,8 Nm
----	--	--------

## 76 – Connecting the battery earth lead



For additional information see:

61 00 ... Safety information on handling the vehicle battery

61 00 / 12 00 ... Notes on disconnecting and connecting the vehicle battery

61 12 ... Notes on the intelligent battery sensor (IBS)

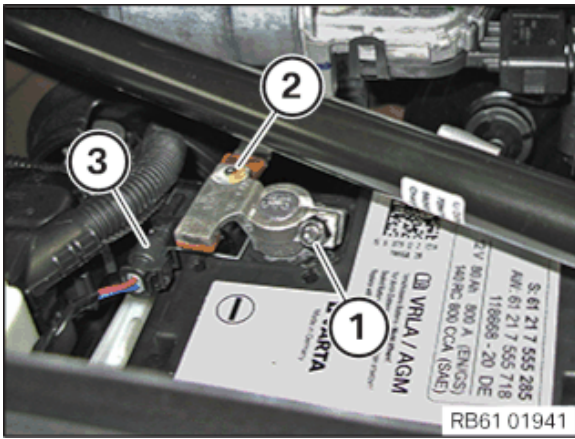

- Remove the protective cover of the positive battery terminal.
- Position the battery earth lead (2).
- Tighten nut (1).

**Battery terminal with IBS positive battery terminal / negative battery terminal**

NutM6	5 Nm
-------	------

- If required, connect the connector (3).

**77 – Installing the upper bulkhead cover**

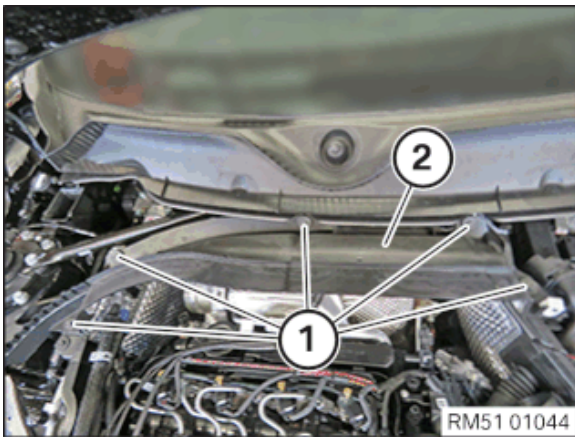

- Feed in and install cover (2) of the bulkhead at the top.
- Tighten the screws (1).

**Bulkhead cover, top**

Screw	Tightening torque	3 Nm
-------	-------------------	------

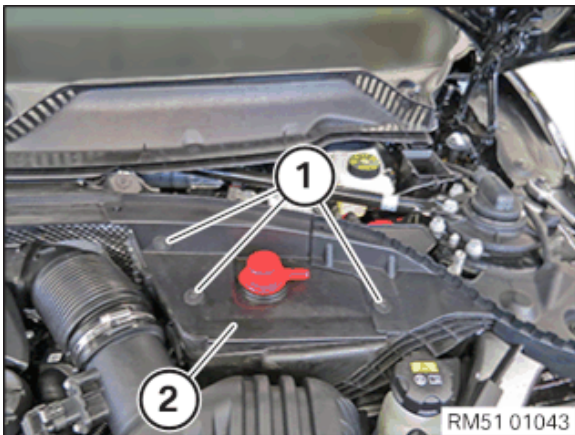

- Guide in and install cover (2).
- Tighten the screws (1).

**Positive battery connection point cover to engine compartment partition wall**

Tightening torque	3 Nm
-------------------	------

**78 – Installing front cowl panel cover**

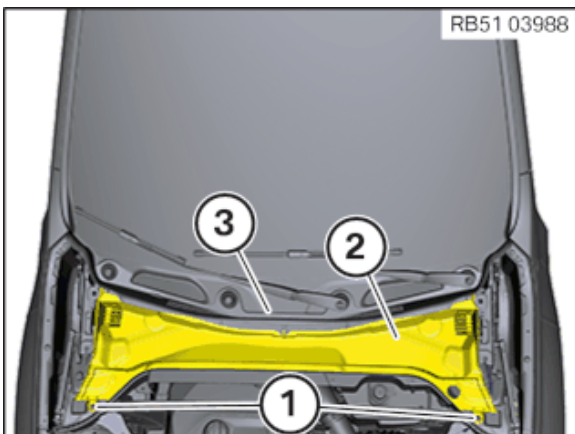

- Insert and install cowl panel cover at front (2) into cowl panel cover at rear (3).
- Check cowl panel cover at front is correctly seated (2).
- Secure expanding rivet (1).

**79 – Install the seal for the bonnet**



Schematic diagram is for example purposes. Some parts may differ in certain details.

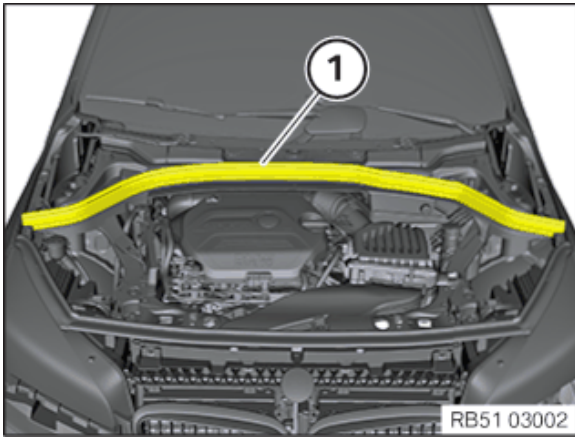

- Install the bonnet seal (1) and ensure correct fit.

## 80 – Installing intake silencer housing

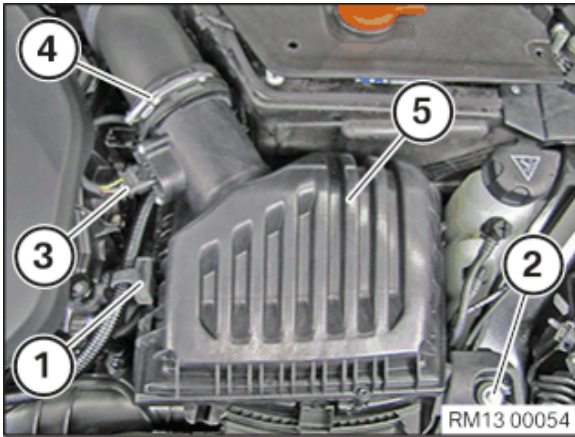

- Insert the intake silencer housing (5) into the rubber mounts and install it.  
Intake filter housing (5) must engage audibly.
- Tighten down screw (2).

### Intake silencer housing to lock bridge

M6X30	Tightening torque	8 Nm
-------	-------------------	------

- Tighten clamp (4).

### Clean air pipe to intake silencer housing

Clamp	Tightening torque	3 Nm
-------	-------------------	------

- Connect and lock the connector (3).  
The connector (3) must engage audibly.
- Insert and install the holder (1).

## 81 – Install the intake neck for the intake filter housing

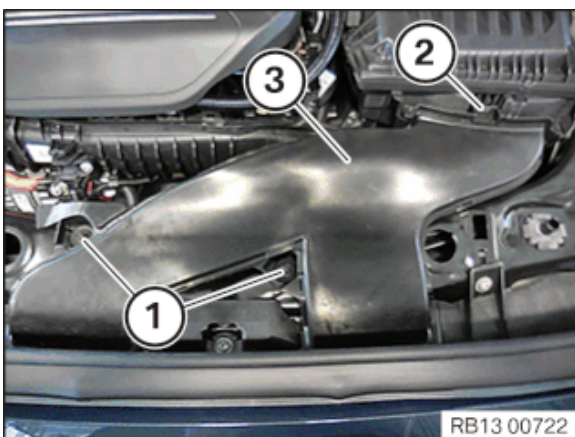

- Insert and install the intake neck (3).  
The lock (2) must audibly engage.
- Tighten nuts (1).

### Intake neck to cross connection

M6	Tightening torque	8 Nm
----	-------------------	------

## 82 – Install acoustic cover



### Damage to the acoustic cover/design cover.

**Jerky movements during disassembly and excessive application of force during installation may result in breakage of the acoustic cover/design cover.**

- Disassemble or mount the acoustic cover/design cover carefully.
- Disassemble or mount snap-lock couplings of the ball pivots one after the other.
- Disassemble or mount acoustic cover/design cover only at temperatures >20 °C.
- Use only distilled water as an auxiliary material during installation, no lubricants.

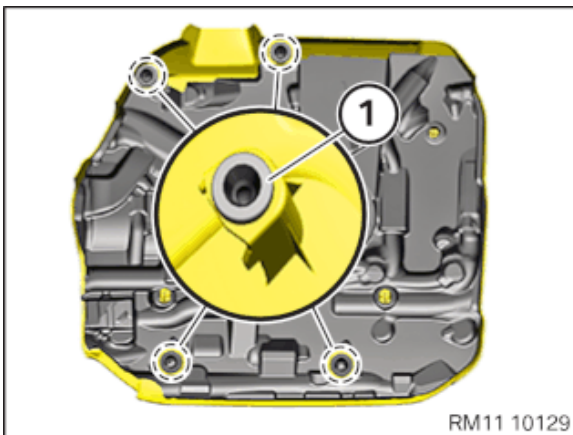

- Check for correct fit of all rubber mounts (1) in the acoustic cover.

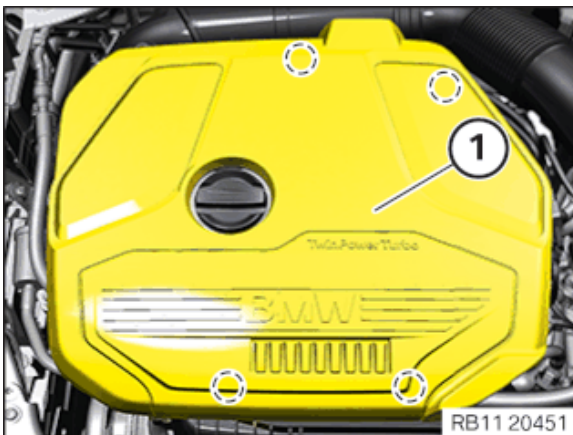

- Clip in the acoustic cover (1) into the holders in the indicated areas.
- Make sure that the acoustic cover (1) engages audibly.

## 83 – Install strut brace



Driving without the strut brace/front-end strut or tension strut is not permitted.

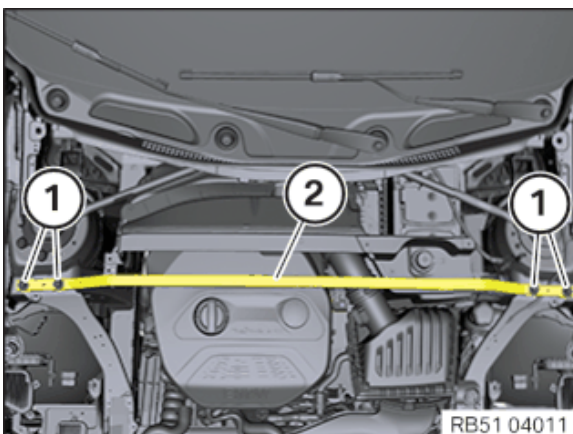

- Install the strut brace (2).
  - Renew screws (1).
- Parts:** Screws
- Tighten the screws (1).

### Cross-brace to spring strut dome

Screw	Renew screw.	Tightening torque	28 Nm
		Angle of rotation	180 °

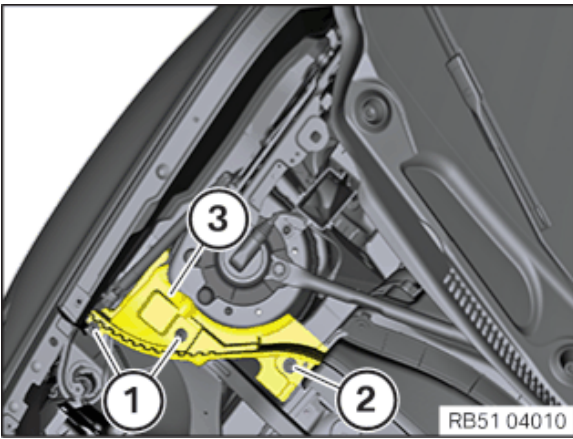

Description is for right component only. The procedure on the left side is identical.

- Install the cover (3).
- Tighten down screw (2).

#### Cover on body

Hexagon screw

Tightening torque

3 Nm

- Install the expanding rivet (1).

## 84 – Bleed the cooling circuit



Filling **without** the vacuum filler device (watering can filling) is **not permitted**.

Non-compliance will result in danger of component and/or engine damage.

Filling specification **absolutely must** be adhered to.

Operation of the vehicle is not permitted unless the filling procedure has been completed. Otherwise, functional limitations (degradation) and/or overheating may occur.

A bleeding procedure is required after a part has been exchanged in the cooling system and/or after refilling the cooling system.



Before starting the automatic cooling system bleeding routine, make sure that the **coolant circuit is filled**. If the cooling system bleeding routine is started while one of the coolant circuits is empty, there is a risk of damage to the electric coolant pump when running it dry.

**Ensure that terminal 15 does not fail during the bleeding procedure.**



#### Life-long fill of coolant!

Do not reuse used coolant.

When replacing and removing components which rely on the corrosion protection effect of the coolant, it is essential to change the coolant. The cooling system must therefore be emptied and refilled.

In the case of other removal work involving the draining of part quantities of coolant, the coolant level must be topped up with new coolant.



In case the cooling system bleeding routine needs to be carried out again: Pull off the ignition key until the vehicle respectively the Digital Motor Electronics (DME) has gone to sleep.



The driving experience switch must not be set to the ECO PRO switch position.



During the cooling system bleeding routine, the electric fan may be activated sporadically.

- Remove the vacuum filler device at the coolant expansion tank.
- Adjust the filling level in the coolant expansion tank to **200 ml** above the maximum mark.
- Close the sealing cap (1) on the coolant expansion tank.

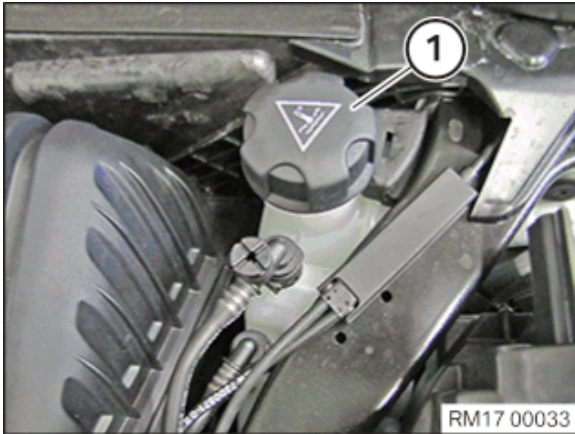

#### Check Result

#### Measure

- [Automated coolant - cooling system bleeding routine](#)

## 85 – Check engine oil level

### Prerequisite

Vehicle is in a horizontal position.



Please comply with instructions in Owner's Handbook.

- Carry out an electronic oil measurement.
- Top up engine oil if necessary.

## 86 – Installing the front underbody protection

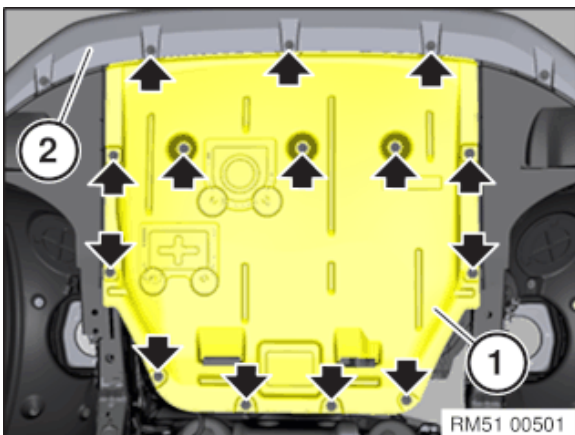

- Guide the front underbody protection (1) in under the bumper panel (2) and position it at the screw points.
- Tighten screws (arrows).

#### Underbody protection front

3 Nm

## 87 – Take bonnet out of the service position



### Shutting bonnet or tailgate.

#### Danger of injury!

- Support bonnet/tailgate in fully open position with the aid of a suitable device.

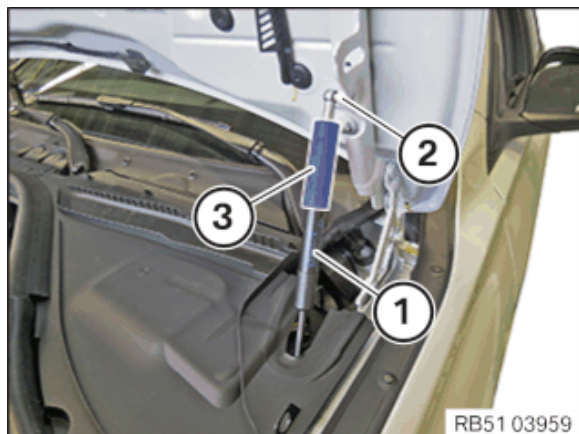

- Support the bonnet by hand.
- Remove the special tool (3) from the ball pin (2).
- Pull off the special tool (3) from the gas pressure spring (1).
- Continue to support the bonnet and repeat the operation on the other side of vehicle.

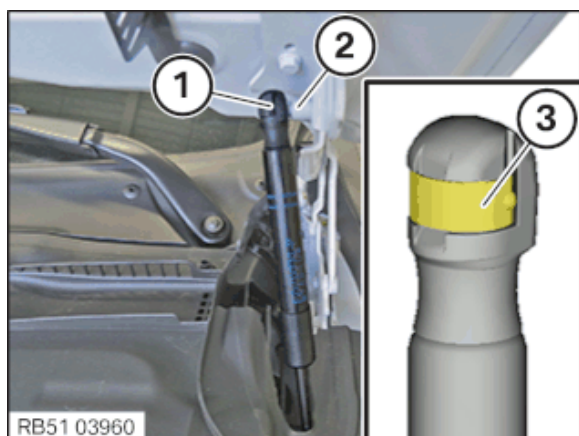

- Check the clamp (3) is fitted correctly.
- Connect ball socket (1) to ball pin (2).
- Continue to support the bonnet and repeat the operation on the other side of vehicle.

## Additional Information

### Overview of Tightening Torques

#### Oil drain plug on oil sump

Used in step [23](#)

M12x1.5	Renew the sealing ring.	Tightening torque	25 Nm
---------	-------------------------	-------------------	-------

#### Oil drain plug / oil filler plug

Used in step [24](#) [60](#)

		Tightening torque	43 Nm
--	--	-------------------	-------

#### Fan cowl on radiator

Used in step [27](#) [66](#)

M6X12		Tightening torque	6 Nm
-------	--	-------------------	------

#### Bracing strut to top cross connection

Used in step [28](#) [67](#)

M8		Tightening torque	25 Nm
----	--	-------------------	-------

#### Air duct to deformation element/cross connection

Used in step [28](#) [67](#)

M6x20 screw		Tightening torque	6 Nm
-------------	--	-------------------	------

<b>Cross connection on support for cross connection</b>			Used in step <a href="#">28</a> <a href="#">67</a>
M6x20		Tightening torque	12 Nm
<b>Transmission mounting</b>			Used in step <a href="#">45</a>
M10	Renew screws.	Jointing torque	40 Nm
		Angle of rotation	90 °
<b>Right engine mount to cylinder head</b>			Used in step <a href="#">45</a>
M10	Renew screws.	Jointing torque	40 Nm
		Angle of rotation	90 °
<b>Clutch slave cylinder to transmission housing</b>			Used in step <a href="#">45</a>
M8		Tightening torque	19 Nm
<b>Battery tray</b>			Used in step <a href="#">45</a>
M8		Tightening torque	19 Nm
<b>Positive battery cable to positive battery terminal</b>			Used in step <a href="#">45</a>
M8		Tightening torque	15 Nm
<b>Refrigerant lines to air-conditioning compressor</b>			Used in step <a href="#">45</a>
M8	Renew sealing rings.	Tightening torque	19 Nm
<b>Exhaust system to catalytic converter</b>			Used in step <a href="#">45</a>
Ribbon cable clamp	Renew flat band clip.	Tightening torque	26 Nm
<b>Output shaft bearing to engine block</b>			Used in step <a href="#">47</a>
M10		Tightening torque	38 Nm
<b>Charge air duct to oil sump</b>			Used in step <a href="#">49</a>
M6		Tightening torque	8 Nm
<b>Rear end of front axle support to body</b>			Used in step <a href="#">51</a>
M14 screw	Renew screw.	Tightening torque	175 Nm
<b>Front axle support, front to body</b>			Used in step <a href="#">51</a>
M12 screw	Renew screw.	Tightening torque	108 Nm
<b>Underbody protection to body</b>			Used in step <a href="#">51</a>
Screw		Tightening torque	3 Nm
<b>Track rod end to swivel bearing</b>			Used in step <a href="#">51</a>
M14	Renew nut.	Tightening torque	175 Nm

<b>Wishbone to swivel bearing</b>			Used in step <a href="#">51</a>
M10	Exclusively use the screw to tighten! Renew screw and nut.	Tightening torque	56 Nm
<b>Holder, wishbone rubber mount, to body</b>			Used in step <a href="#">52</a>
M10 screw	Renew screw.	Jointing torque	56 Nm
		Angle of rotation	90 °
<b>Holder with rubber mount to front axle support</b>			Used in step <a href="#">52</a>
M12 screw			100 Nm
<b>Deformation element, bottom, to adapter plate, front axle carrier</b>			Used in step <a href="#">52</a>
Screw		Tightening torque	11,8 Nm
<b>Washer fluid reservoir bracket to front axle support adapter plate</b>			Used in step <a href="#">52</a>
Screw		Tightening torque	10 Nm
<b>Lower steering shaft to steering gear</b>			Used in step <a href="#">53</a>
M10	Clean screw thread and remove remains of screw locking agent. Renew screw.	Tightening torque	28 Nm
<b>Steering column cover to bulkhead</b>			Used in step <a href="#">53</a>
Plastic nut		Tightening torque	3 Nm
<b>Holder to front axle support</b>			Used in step <a href="#">54</a>
Oval-head screw TS5 x 16		Tightening torque	2,6 Nm
<b>Anti-roll bar link to anti-roll bar/spring strut</b>			Used in step <a href="#">56</a>
M10	Renew nut.	Tightening torque	56 Nm
<b>Starter motor to transmission</b>			Used in step <a href="#">59</a>
M8x45		Tightening torque	19 Nm
<b>Battery positive lead to starter</b>			Used in step <a href="#">59</a>
M8		Tightening torque	13,5 Nm
<b>Wheel arch cover to body</b>			Used in step <a href="#">61</a>
Screw		Tightening torque	2,5 Nm
<b>Wheel arch cover to body</b>			Used in step <a href="#">61</a>
Plastic nut		Tightening torque	3 Nm
<b>Brake disc to front wheel hub</b>			Used in step <a href="#">62</a>
M8		Tightening torque	16 Nm

<b>Brake disc to rear wheel hub</b>		Used in step	<a href="#">62</a>
M8		Tightening torque	16 Nm
<b>Wheel bolts</b>		Used in step	<a href="#">62</a>
M 14/AF 17	Screw in wheel bolts and evenly tighten crosswise by hand in order to centre the wheel rim.	Tightening torque	140 Nm
	Tighten wheel bolts to the prescribed tightening torque with a calibrated torque wrench in a crosswise sequence.	Check	140 Nm
	Check all the wheel bolts in the same order or retighten to the prescribed tightening torque again.		
<b>Electronics box to battery tray</b>		Used in step	<a href="#">72</a>
M8X16		Tightening torque	15 Nm
<b>Cover to electronics box</b>		Used in step	<a href="#">74</a>
RF5x26.5		Tightening torque	2,5 Nm
<b>Positive battery terminal to battery</b>		Used in step	<a href="#">74</a>
NutM6		Tightening torque	5 Nm
<b>Tension strut to spring strut dome/battery tray</b>		Used in step	<a href="#">74</a>
M8		Tightening torque	19 Nm
<b>Battery terminal rail to battery tray</b>		Used in step	<a href="#">75</a>
M8			19 Nm
<b>Battery terminal with IBS positive battery terminal / negative battery terminal</b>		Used in step	<a href="#">75</a> <a href="#">76</a>
NutM6			5 Nm
<b>Trailing link</b>		Used in step	<a href="#">75</a>
M8		Tightening torque	19 Nm
<b>Battery cover</b>		Used in step	<a href="#">75</a>
M8			2,8 Nm
<b>Bulkhead cover, top</b>		Used in step	<a href="#">77</a>
Screw		Tightening torque	3 Nm
<b>Positive battery connection point cover to engine compartment partition wall</b>		Used in step	<a href="#">77</a>
		Tightening torque	3 Nm
<b>Intake silencer housing to lock bridge</b>		Used in step	<a href="#">80</a>
M6X30		Tightening torque	8 Nm
<b>Clean air pipe to intake silencer housing</b>		Used in step	<a href="#">80</a>
Clamp		Tightening torque	3 Nm

**Intake neck to cross connection**Used in step [81](#)

M6		Tightening torque	8 Nm
----	--	-------------------	------

**Cross-brace to spring strut dome**Used in step [83](#)

Screw	Renew screw.	Tightening torque	28 Nm
		Angle of rotation	180 °

**Cover on body**Used in step [83](#)

Hexagon screw		Tightening torque	3 Nm
---------------	--	-------------------	------

**Underbody protection front**Used in step [86](#)

3 Nm

**Overview of Special Tools****2 353 020 Support****Common**Used in step [1](#)

## Usage

For service position of engine compartment lid Associated contour-graphic silhouette foil can be ordered under: 83 30 2 356 848. Further information on the contour-graphic silhouette foil can be found in service information 00 22 13 (969).

Included in the tool or work

Storage location A74

Replaced by

In connection with

SI-Number 01 11 13 (960)

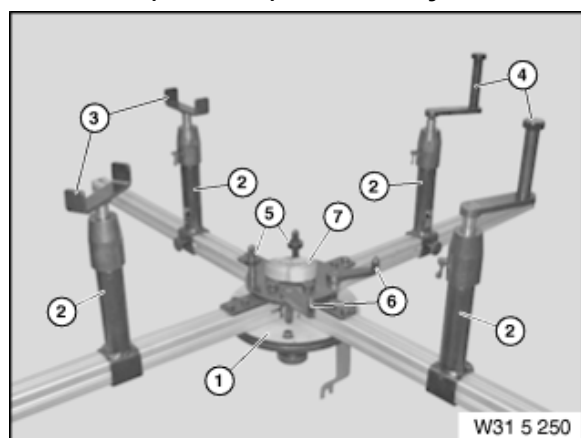
**0 495 817 (31 5 251) Basic body****Common**Used in step [38](#) [51](#)

## Usage

(Basic body) No longer available separately, only via special tool set 31 5 250 (83 30 0 495 567)

Included in the tool or work

0 495 567

Storage location

Replaced by

In connection with

SI-Number 01 24 06 (309)

**0 490 133 (00 2 030) Device****Common**Used in step [38](#) [51](#)

## Usage

(universal hydraulic lifter base unit) Chassis and hydraulic lifter - For removing and

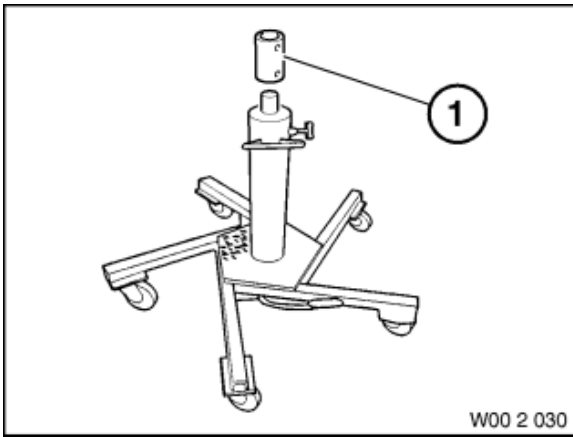

installing rear axle supports and gearboxes.  
Also for soft top mounts. Is replaced by 81 22 2 219 012

Included in the tool or work  
Storage location  
Replaced by  
In connection with  
SI-Number 01 05 90 (207)

**Consisting of**

Pos	BMW Order number	Replaced by	Designation	In Connection with
1	<a href="#">0 490 134</a> <a href="#">(00 2 031)</a>		<b>Adapter</b> (adapter for gearbox holder) Model series: E30, E31, E32, E34, E36	

**0 495 821 (31 5 255) Adapter**

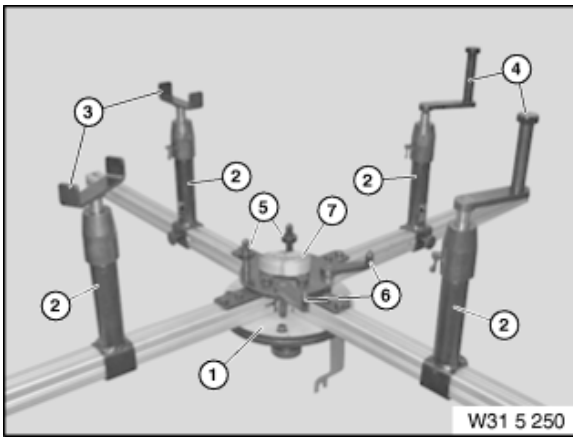

<b>Common</b>		Used in step	38
Usage	(Mounting adapter for bores (2 pieces)) Delivery while stocks last - as of 02/2019.		
Included in the tool or work	0 495 567		
Storage location			
Replaced by			
In connection with			
SI-Number	01 24 06 (309)		

**0 495 819 (31 5 253) Adapter**

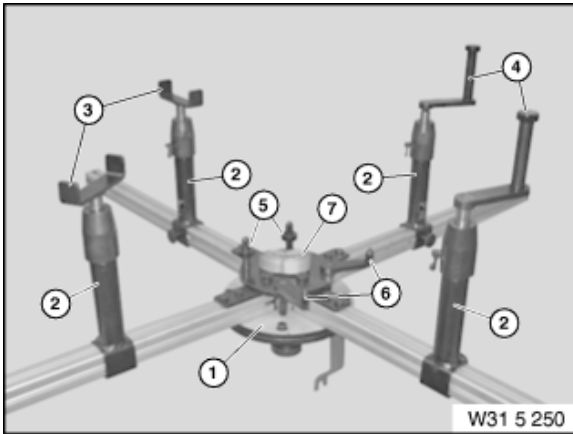

<b>Common</b>		Used in step	38
Usage	(Mounting adapter for U-profile (2 pieces)) Delivery while stocks last - as of 02/2019.		
Included in the tool or work	0 495 567		
Storage location			
Replaced by			
In connection with			
SI-Number	01 24 06 (309)		

**0 496 080 (33 5 206) Belt**

<b>Common</b>		Used in step	38 51
Usage	(Tensioning strap) Delivery while stocks last		

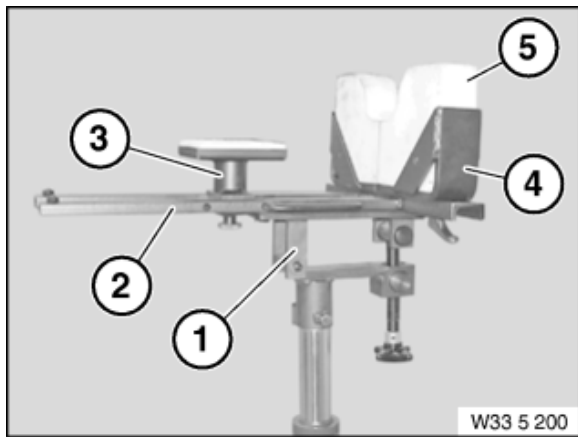

- as of 02/2019.

Included in the tool or work 0 496 009  
 Storage location  
 Replaced by  
 In connection with  
 SI-Number

**0 496 698 (23 0 120) Puller**



**Common** Used in step [39](#) [40](#) [41](#)

Usage For pulling out the radial shaft seal on the output (differential) left/right.

Included in the tool or work

Storage location A87

Replaced by

In connection with

SI-Number 01 11 09 (550)

**0 496 565 (13 5 160) Fastener**

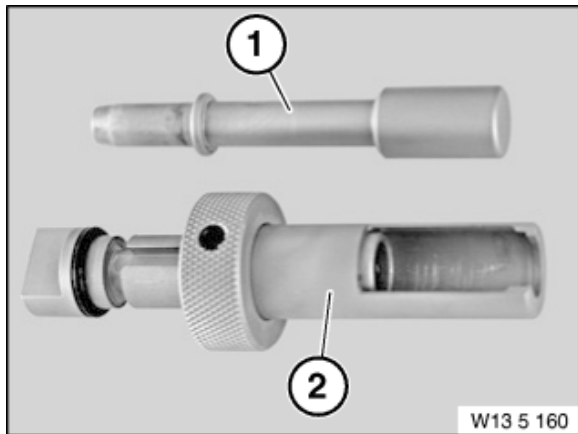

**Common** Used in step [44](#) [45](#)

Usage (Caps (2x)) To close off the fuel lines when removing and installing the engine.

Included in the tool or work

Storage location B26

Replaced by

In connection with

SI-Number 01 22 08 (498)

**Consisting of**

Pos	BMW Order number	Replaced by	Designation	In Connection with
1	<a href="#">0 496 567 (13 5 161)</a>		<b>Fastener</b> (Cap (2 piece)) For sealing the quick connectors Deletion, only available via tool set	

**Fastener**  
 (Cap (2 x)) To close off the fuel lines.  
 Discontinued, can only be ordered using complete tool

2 [0 496 568](#)  
 ([13 5 162](#))

**0 496 568 (13 5 162) Fastener**

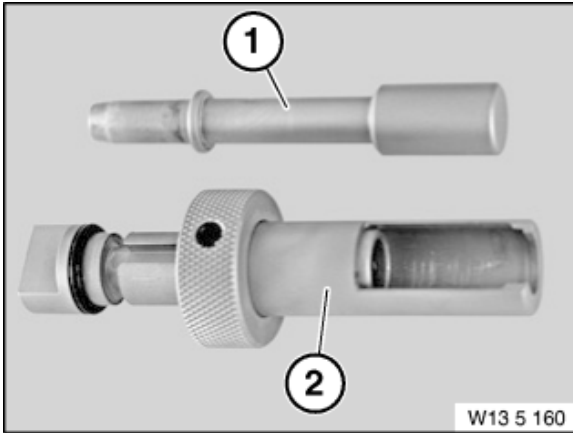

<b>Common</b>		Used in step	<a href="#">44</a>	<a href="#">45</a>
Usage	(Cap (2 x)) To close off the fuel lines. Discontinued, can only be ordered using complete tool			
Included in the tool or work	0 496 565			
Storage location				
Replaced by				
In connection with				
SI-Number				

**2 305 379 Accessories**



<b>Common</b>		Used in step	<a href="#">44</a>
Usage	Holder set for MHT 1200 major assembly table lift and new generation (from 2020)		
Included in the tool or work			
Storage location	Individual		
Replaced by			
In connection with	Mobile major assembly table lift MHT 1200 81222184136		
SI-Number	06 01 10 (649)		

**2 184 136 Mobile unit table lift**

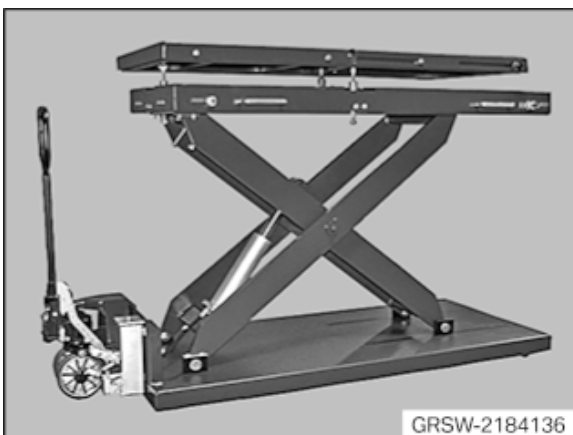

<b>Common</b>		Used in step	<a href="#">44</a>
Usage	Table lift MHT 1200		
Included in the tool or work			
Storage location			
Replaced by			
In connection with			
SI-Number	06 01 10 (649)		

**2 357 221 Fixture**

<b>Common</b>		Used in step	<a href="#">44</a>
---------------	--	--------------	--------------------

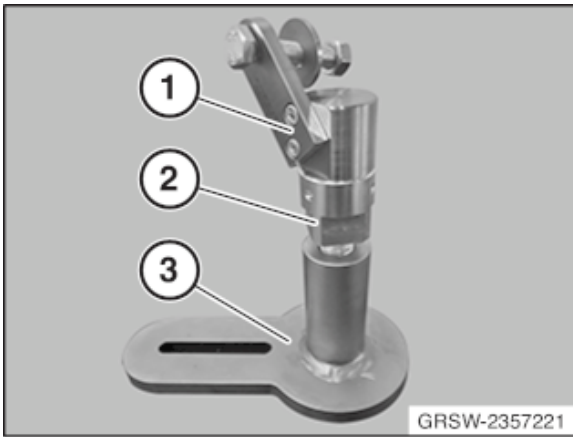

Usage Fixture of drive unit (electrical machine/transmission and optional range extender) on the mobile lifting table MHT 1200 81 22 2 184 136 IMPORTANT: required three times! Delivery specification 1 pcs. Was valid as campaign for BMW i Aftersales Basic. Not a mandatory tool since the BMWi changeover to iPerformance. Fixture foot 83302357221\_C including bracket 83302357221\_B and tab 83302357221\_A

Included in the tool or work

Storage location Individual

Replaced by

In connection with

SI-Number 01 22 13 (988)

### 2 409 230 Mandrel



**Common** Used in step [46](#) [47](#) [48](#)

Usage For installing the rear-wheel drive of Transmission output shaft le./ri. silhouette foil is contained in delivery specification. Further information on the contour-graphic silhouette foil is included in service information 00 22 13 (969).

Included in the tool or work

Storage location A75

Replaced by

In connection with

SI-Number 01 56 14 (214)

### 0 496 521 (00 2 230) Pliers

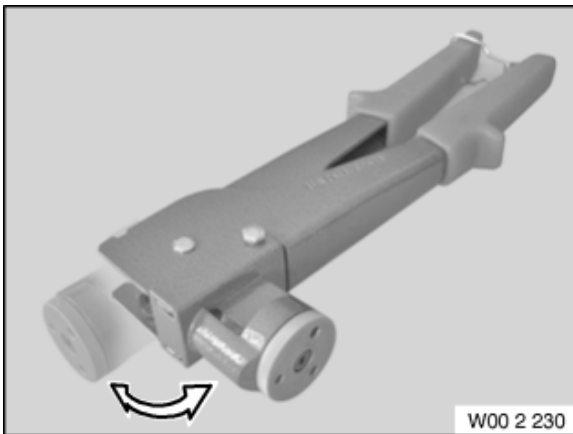

**Common** Used in step [61](#)

Usage (Blind rivet pliers for plastic rivets) For shaft diameters of 3.5 mm, 3.9 mm and 4.5 mm

Included in the tool or work

Storage location C25

Replaced by

In connection with

SI-Number 01 17 08 (478)

### 2 344 011 Tool

**Common** Used in step [62](#)

Usage Tool (wheel hub grinder) for cleaning the



connection of the wheel rim (wheel contact face) to the wheel hub.

Included in the tool or work  
Storage location  
Replaced by  
In connection with  
SI-Number 08 08 12 (872)

### 0 494 417 (17 0 100) Tester

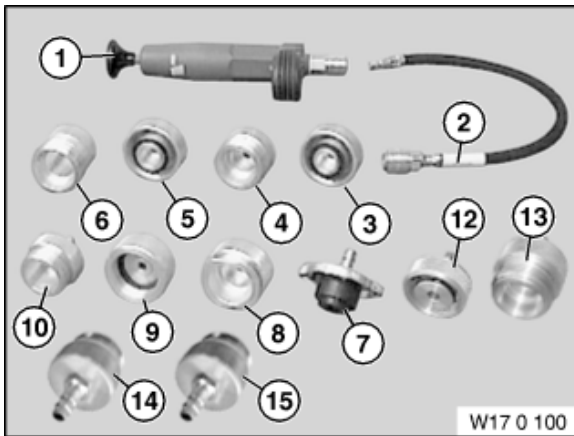

**Common** Used in step [70](#)

Usage For checking engine cooling system on watertightness. For checking radiator cap.  
Included in the tool or work  
Storage location Individual  
Replaced by  
In connection with  
SI-Number 01 07 02 (884)

#### Consisting of

Pos	BMW Order number	Replaced by	Designation	In Connection with
5	<a href="#">0 494 422</a> <a href="#">(17 0 105)</a>		<b>Adapter</b> For radiator cap (sawtooth thread)	
10	<a href="#">0 494 427</a> <a href="#">(17 0 111)</a>		<b>Adapter</b> For radiator cap R53/W11, R50/W17 adapter replaced 17 0 052.	
1	<a href="#">0 494 418</a> <a href="#">(17 0 101)</a>		<b>Pump</b> Replacement part for set 8330 0494417 (170100)	
2	<a href="#">0 494 419</a> <a href="#">(17 0 102)</a>		<b>Hose</b> (hose with quick-release coupling)	
3	<a href="#">0 494 420</a> <a href="#">(17 0 103)</a>		<b>Adapter</b> For radiator cap (normal thread)	
4	<a href="#">0 494 421</a> <a href="#">(17 0 104)</a>		<b>Adapter</b> For radiator cap (normal thread)	
6	<a href="#">0 494 423</a> <a href="#">(17 0 106)</a>		<b>Adapter</b> For radiator cap (sawtooth thread)	

7	<a href="#">0 494 424</a> ( <a href="#">17 0 107</a> )	<b>Adapter</b> For radiator cap R50 / W10
8	<a href="#">0 494 425</a> ( <a href="#">17 0 108</a> )	<b>Adapter</b> For radiator cap R50 / W10
9	<a href="#">0 494 426</a> ( <a href="#">17 0 109</a> )	<b>Adapter</b> For radiator connection R53/W11, R50/W17 adapter corresponds to 17 0 051
11	<a href="#">0 494 428</a> ( <a href="#">17 0 112</a> )	<b>Case</b>
12	<a href="#">0 494 642</a> ( <a href="#">17 0 113</a> )	<b>Adapter</b> For radiator cap Model series: E60, E61, E63, E64 SI no.: 1 08 03 (988)
13	<a href="#">0 494 643</a> ( <a href="#">17 0 114</a> )	<b>Adapter</b> For radiator cap Model series: E60, E61, E63, E64 SI no.: 1 08 03 (988)
14	<a href="#">0 495 889</a> ( <a href="#">17 0 115</a> )	<b>Adapter</b> For radiator cap Model series: N12, N14

### Replacement tools:

#### 0 495 221 (36 1 323) Wheel stud

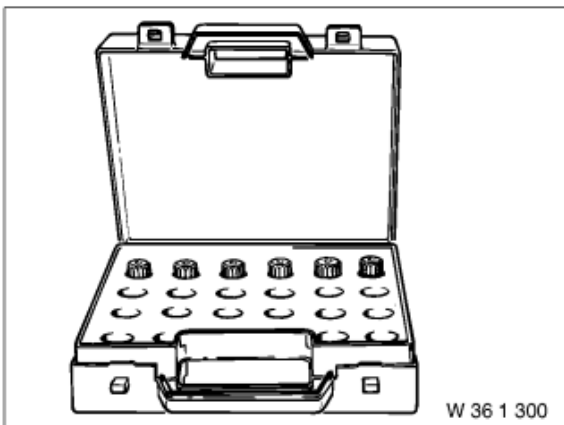

#### Common

Used in step [17](#)

Usage	(Code 30) Code 39 available separately, (see EPC) under 36 13 1 181 259
Included in the tool or work	0 492 518
Storage location	
Replaced by	
In connection with	
SI-Number	

#### 0 495 224 (36 1 326) Wheel stud

#### Common

Used in step [17](#)

Usage	(Code 33) With centring bore available separately, (see EPC) under 36 13 6 765 546
Included in the tool or work	0 492 518
Storage location	

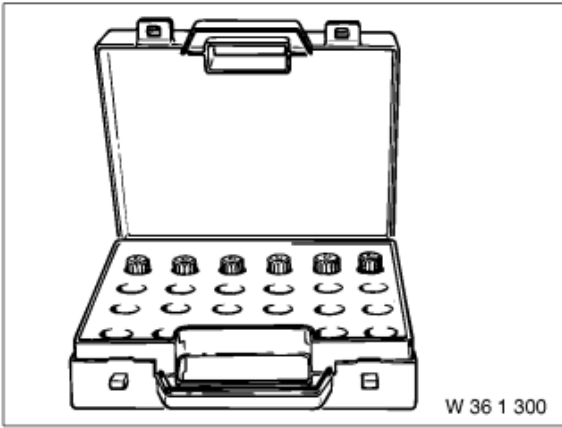

Replaced by  
 In connection  
 with  
 SI-Number

**0 495 225 (36 1 327) Wheel stud**

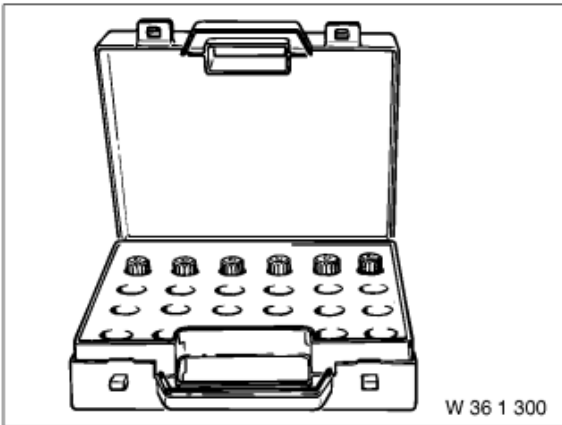

**Common** Used in step [17](#)

---

Usage (Code 34) With centring bore available separately (see EPC) under 36 13 6 765 547

Included in the tool or work 0 492 518

Storage location

Replaced by

In connection with

SI-Number

**0 495 226 (36 1 328) Wheel stud**

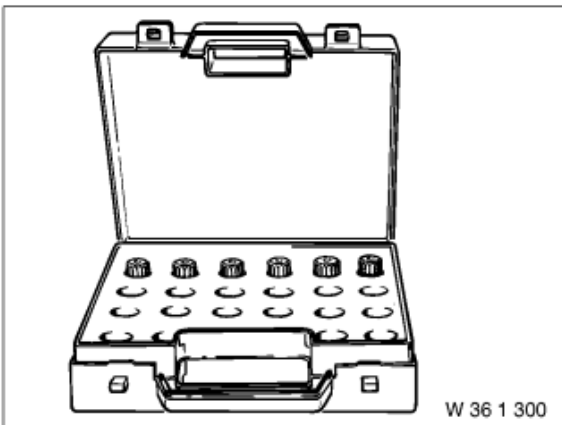

**Common** Used in step [17](#)

---

Usage (Code 35) With centring bore available separately, (see EPC) under 36 13 6 762 340

Included in the tool or work 0 492 518

Storage location

Replaced by

In connection with

SI-Number

**0 495 227 (36 1 329) Wheel stud**

**Common** Used in step [17](#)

---

Usage (Code 36) With centring bore available separately (see EPC) under 36 13 6 762 341

Included in the tool or work 0 492 518

Storage location

Replaced by

In connection

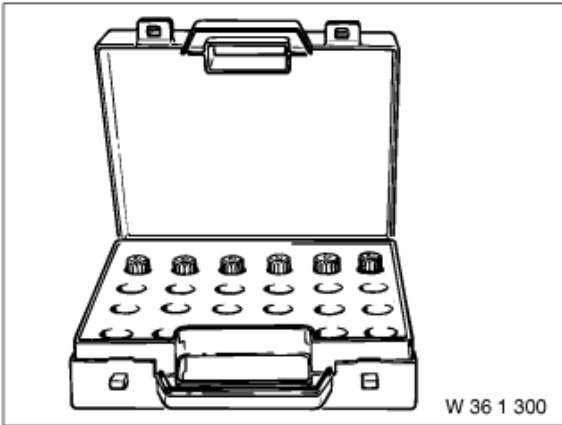

with  
SI-Number

**0 495 228 (36 1 331) Wheel stud**

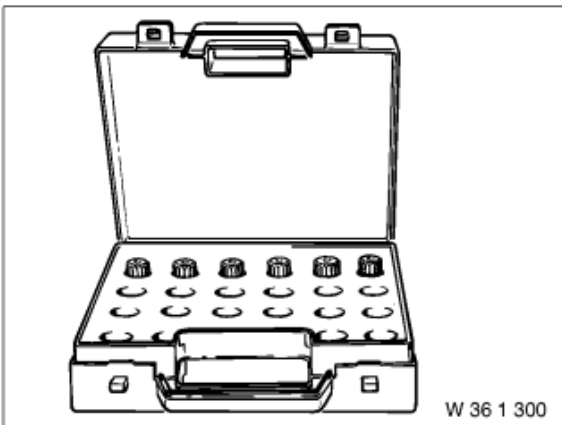

<b>Common</b>		Used in step <a href="#">17</a>
Usage	(Code 37) With centring bore available separately (see EPC) under 36 13 6 762 342	
Included in the tool or work	0 492 518	
Storage location		
Replaced by		
In connection with		
SI-Number		

**0 495 229 (36 1 332) Wheel stud**

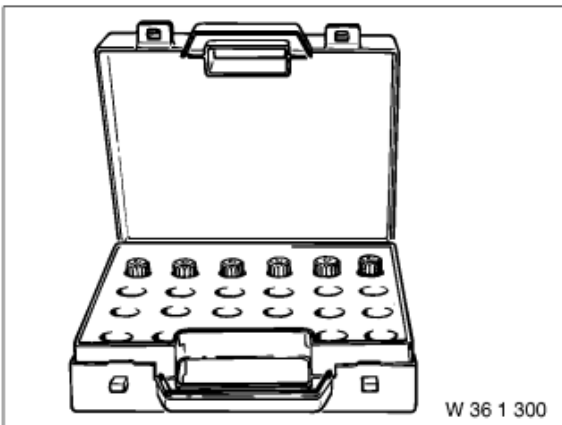

<b>Common</b>		Used in step <a href="#">17</a>
Usage	(Code 38) With centring bore available separately (see EPC) under 36 13 6 762 343	
Included in the tool or work	0 492 518	
Storage location		
Replaced by		
In connection with		
SI-Number		

**0 495 230 (36 1 333) Wheel stud**

<b>Common</b>		Used in step <a href="#">17</a>
Usage	(Code 40) With centring bore available separately (see EPC) under 36 13 6 762 344	
Included in the tool or work	0 492 518	
Storage location		
Replaced by		
In connection		

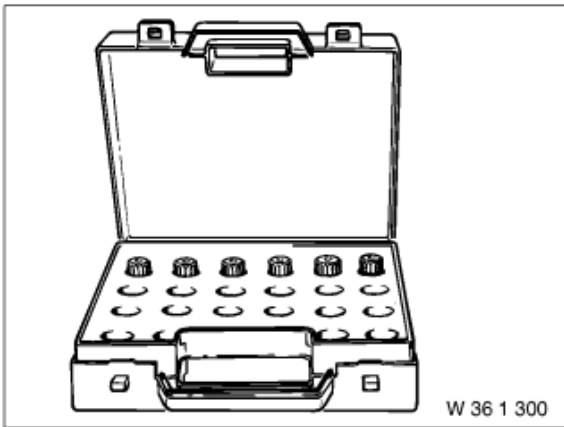

with  
SI-Number

## Overview Technical Data

<b>Transmission oil capacity</b>	Used in step <b>60</b>
Transmission oil GS6-58/59BG/DG	1,9 l
Transmission oil: Technically suitable manual gearbox oil	
<b>Engine oil B38A15M1/B38A15U1</b>	Used in step <b>68</b>
Capacity of engine oil	4.5 l
Engine oil: Technically suitable engine oils for BMW Group engines	
<b>Coolant filling quantity in the cooling system</b>	Used in step <b>70</b>
B38A15M1, B38A15U1, B36A15M1 with manual gearbox without auxiliary radiator	6,75 l
B38A15M1, B38A15U1, B36A15M1 with manual gearbox with auxiliary radiator	7,45 l
B38A15M1, B38A15U1, B36A15M1 with automatic transmission without auxiliary radiator	7,0 l
B38A15M1, B38A15U1, B36A15M1 with automatic transmission with auxiliary radiator	7,7 l
B38A15M1, B38A15U1, B36A15M1 with double-clutch transmission without auxiliary radiator	7,1 l
B38A15M1, B38A15U1, B36A15M1 with double-clutch transmission with auxiliary radiator	7,8 l
Expendable materials: Technically suitable antifreeze and corrosion inhibitor	

## Links

<b>Functional descriptions</b>	Used in step
<a href="#">Automated coolant - cooling system bleeding routine</a>	84
<b>Repair instructions (PRE)</b>	Used in step
<a href="#">Draw off the contaminated R1234yf refrigerant and dispose of it</a>	42
<a href="#">Repair notes on renewing the engine</a>	
<b>General repair instructions</b>	Used in step

<a href="#">12 00 ... Instructions for removal and replacement of control units</a>	11 74
<a href="#">64 52 ... Instructions for opening and part exchange in refrigerant circuit</a>	71
<a href="#">61 20 ... Notes on AGM battery</a>	76
<a href="#">61 12 ... Notes on intelligent battery sensor (IBS)</a>	76
<a href="#">61 00 ... Notes for disconnecting and connecting battery</a>	76

## Repair instructions

## Used in step

<a href="#">61 35 ... Notes on ESD protection (Electro Static Discharge)</a>	11 12 30 73
<a href="#">61 35 ... Notes on ESD protection (Electro Static Discharge)</a>	11 12 30
<a href="#">61 13 ... Unlocking and disconnecting different plug connections</a>	11 12 73
<a href="#">64 50 ... Safety information for handling tetrafluorethane refrigerant R134a</a>	42 43
<a href="#">64 50 ... Notice of repair work on air conditioning</a>	42 43 71
<a href="#">64 50 ... Notes regarding refrigerant (R134a, R1234yf) and refrigerant oil (Sanden SP-A2)</a>	42
<a href="#">17 00 ... Notes for working on cooling system</a>	70
<a href="#">64 50 ... Filling refrigerant oil by means of injection</a>	71
<a href="#">00 ... Raising the vehicle using a vehicle hoist</a>	

## Operating materials

## Used in step

<a href="#">14.0 Automatic transmission fluid for ZF-transmission GA8HP45Z / GA8HP50Z / GA8HP70Z / GA8HP90Z / GA8P70H / GA8P75H / GA8HP75Z</a>	24
<a href="#">2.0 Grease for wheel centring</a>	62
<a href="#">3.0 Technically appropriate engine oils for BMW Group engines</a>	68

## Operating materials

## Used in step

<a href="#">Main group 17</a>	70
-------------------------------	----

For informational purposes only. The information on this website is provided AS-IS with no warranties, express or implied, and is not guaranteed to be error-free, up-to-date or complete. NewTIS and BMW assume no liability for any loss or damage arising from the use or reliance on the information and content on this website. The content on this website is subject to change without notice.



### Special tools required:

- [00 2 030](#)
- [23 4 150](#)
- [11 6 480](#)



### Attention!

To prevent heavy damage to the engine block, the protruding thread of the transmission bolts absolutely must be checked for damage and corrosion **before removal**.

If there are signs of corrosion, the rust must be removed and the threads must be cleaned **before removal**.

Replace rusted, damaged screws.

Failure to comply with this instruction will result in serious damage to the engine block and transmission.



### Safety information:

Before removing the transmission, it is **essential** to check the tight fit of the engine mount and ensure that the rubber coating of the engine mount is in perfect condition. If the rubber coating is porous and has cracks, remove the [transmission with engine](#).



### Note:

After completion of work, [check transmission oil level](#).



### Attention!

Use only the [approved automatic transmission oil](#) in this automatic transmission.

Failure to comply with this requirement will result in serious damage to the automatic transmission!

### Attention!

An incorrectly adjusted gearshift mechanism can result in tooth meshing noise being transmitted to the passenger compartment.

Adjust [selector lever](#).



### Necessary preliminary work:

- Remove [vehicle battery](#).
- Secure engine in [installation position](#).
- Loosen the right [wheel arch cover](#).
- Remove [front axle support](#).
- **No wheel alignment is required for removal and installation of front axle support.**
- Remove [starter motor](#).
- Remove [left](#) output shaft only at transmission end and hang up.
- Remove [right](#) output shaft only at transmission end and hang up.



### Removal:

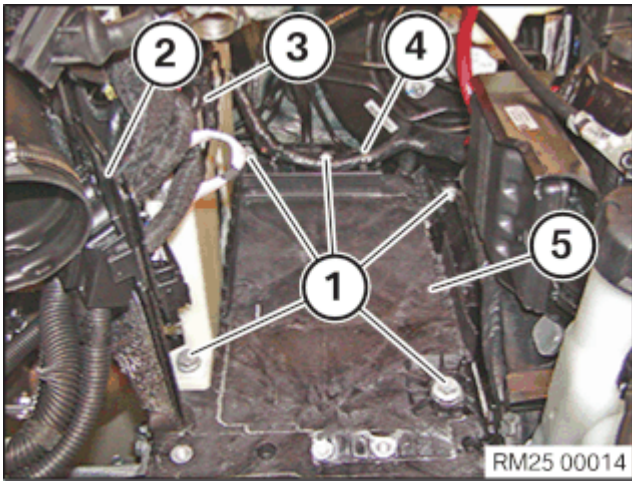

Release screws (1).

Release and remove the vehicle battery partition wall (2) from the bracket.

Release control unit (3) from the bracket.

Release wiring harness (4) from the battery tray (5).

Remove battery tray (5).

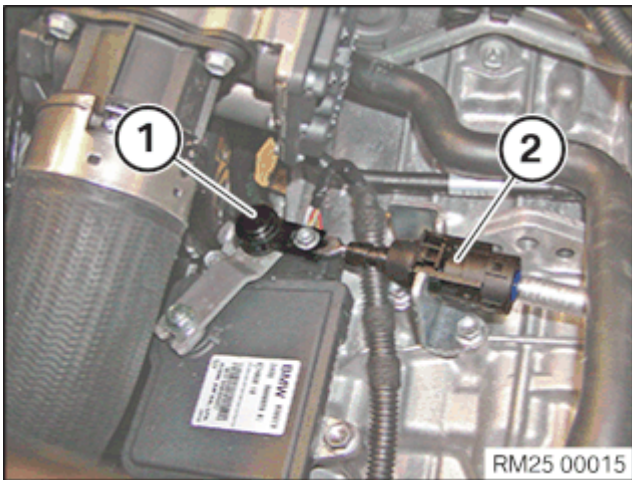

Release ball socket (1) from ball stud.

Release the cable (2) from the support angle.

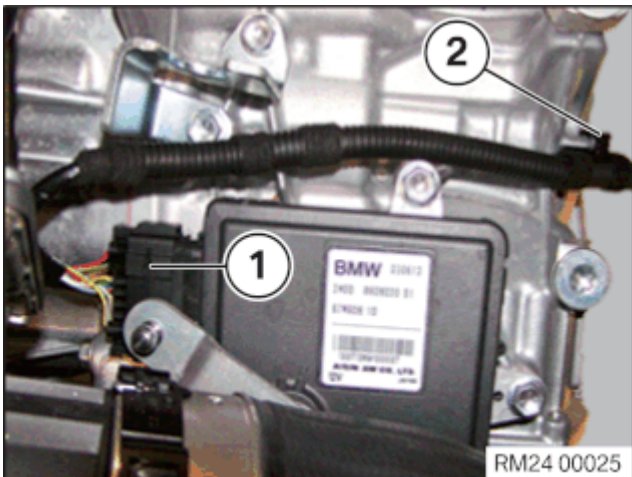

Unlock connector (1).

Loosen clamp (2) with wiring harness from transmission and place to one side.

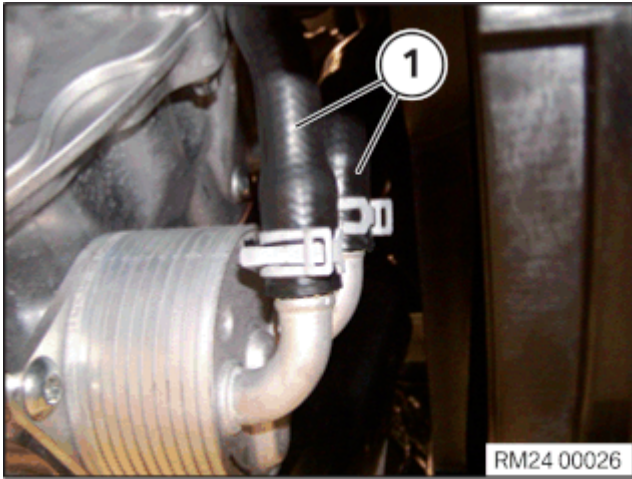

**Attention!**

[Follow notes for carrying out repair work on the cooling system.](#)

Unfasten hose clamps.

Disconnect the coolant hoses (1) from the transmission oil cooler.

Catch the emerging coolant.

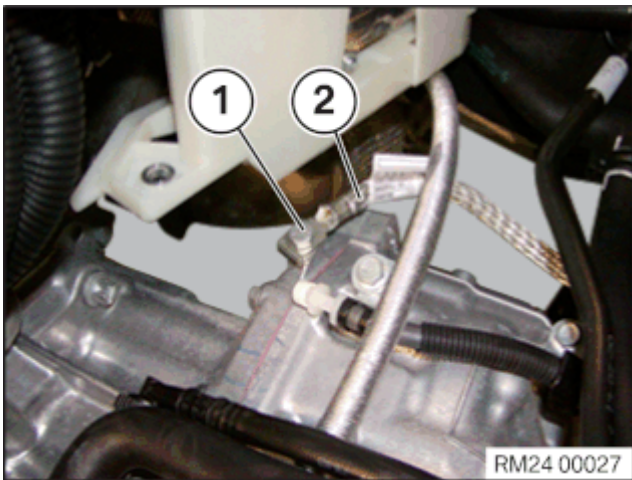

Release screw (1).

Loosen ground strap (2) from transmission and place to one side.

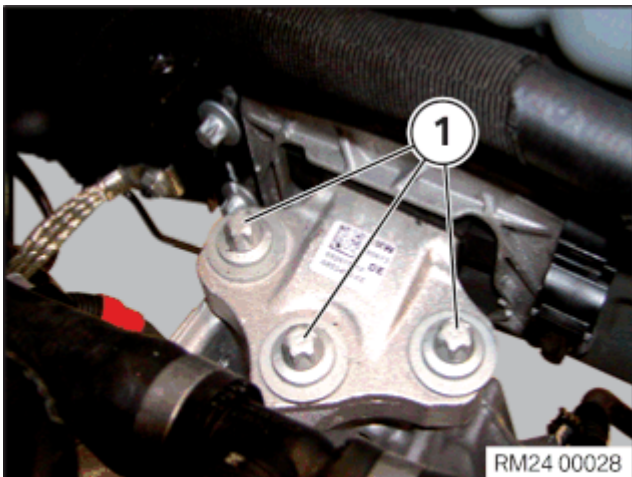

Release screws (1).

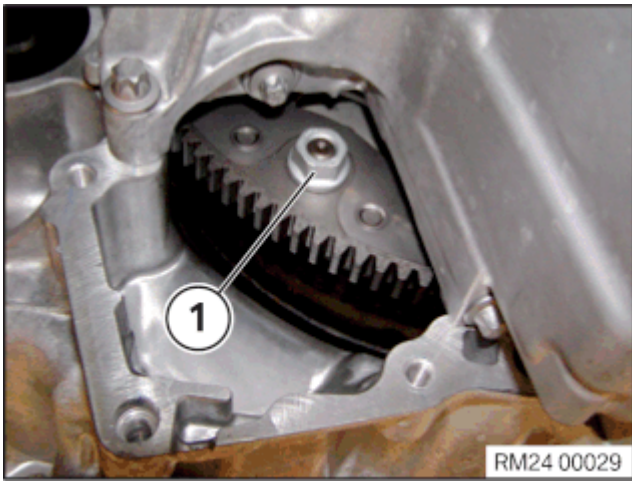

Crank engine with special tool [11 6 480](#) at vibration damper in direction of rotation.

Release nut (1) on torque converter.

Crank engine further and release remaining 5 nuts.

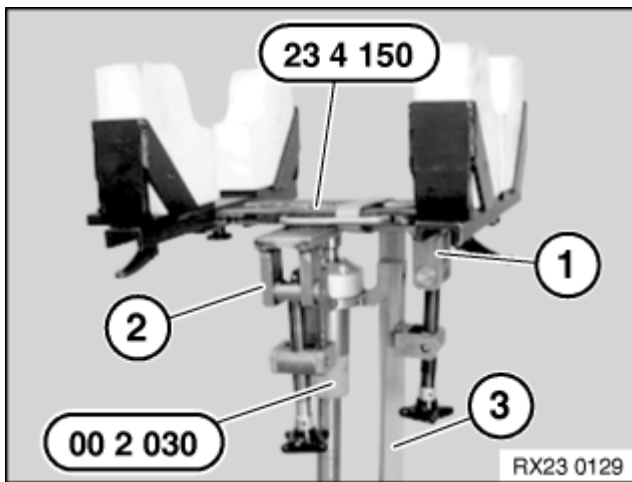

Supporting transmission:

Support the transmission with special tool [23 4 150](#) and [00 2 030](#).

Secure transmission with the tensioning strap (3).

Tasks are described in [gearbox holder](#).

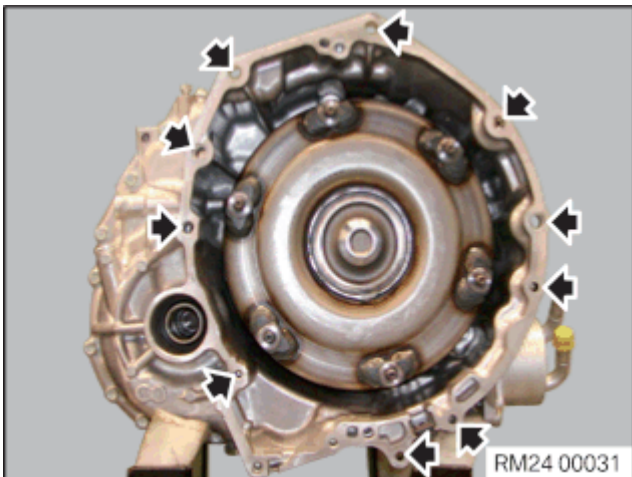

Release bolts and remove the transmission. **Attention!**

Transmission mounting bolts differ in length.

Note installation position.

Installing the wrong bolts may cause serious damage.



**Installation:**

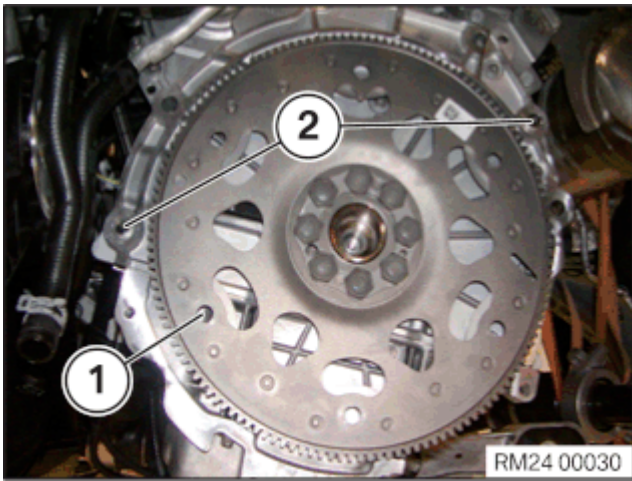

Bore hole (1) of driving plate must be accessible from recess on engine oil sump. Check that fitting sleeves (2) are correctly fitted.

Replace damaged fitting sleeves.

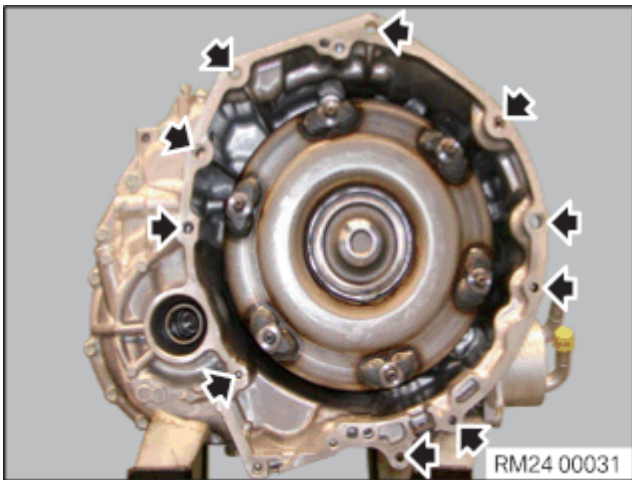

Rotate torque converter until bore hole in torque converter is flush with bore hole in drive plate.

Flange-mount automatic transmission to engine and screw on.

Tightening torque [24 00 1AZ](#).

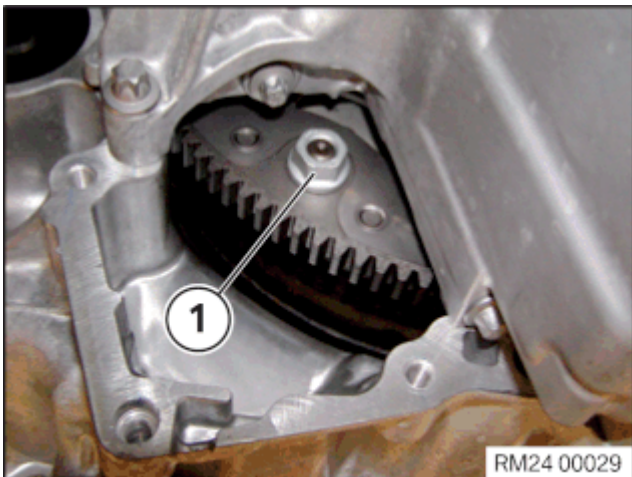

Crank engine with special tool [11 6 480](#) at vibration damper in direction of rotation.

**Parts:** Replace nuts (1).

Screw 6 nuts (1) on torque converter.

Tightening torque [24 40 1AZ](#).

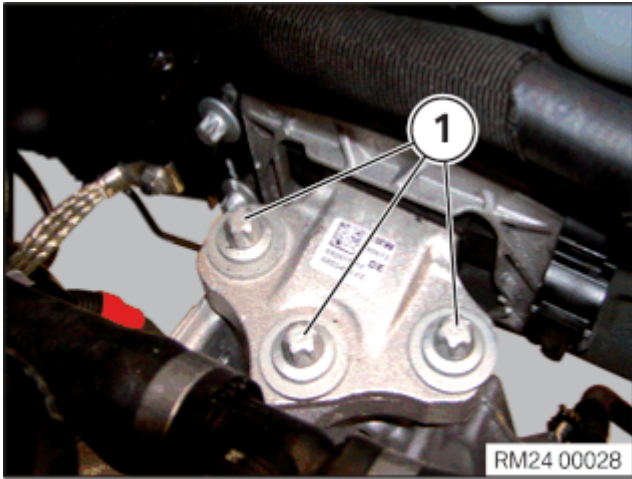

Screw the transmission on the transmission mount with the screws (1).

Tightening torque [22 32 1AZ](#).

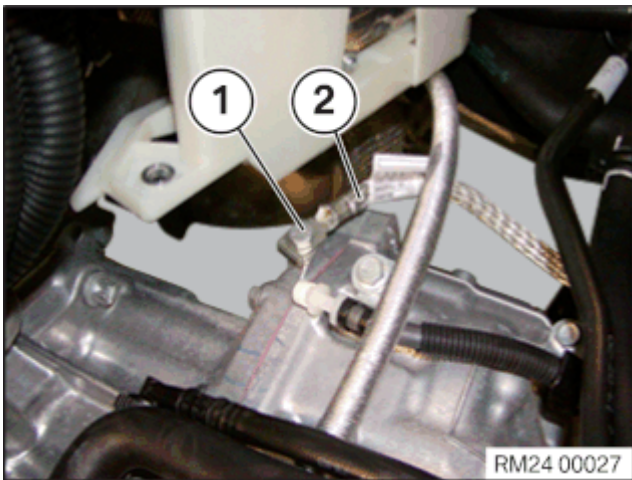

Screw ground strap (2) on the transmission with the screw (1).

Tightening torque [24 00 2AZ](#).

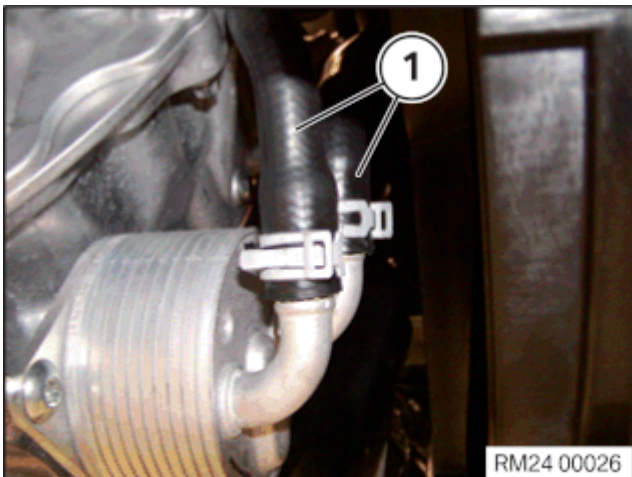

Slide the coolant hoses (1) onto the transmission oil cooler.

Secure hose clamps.

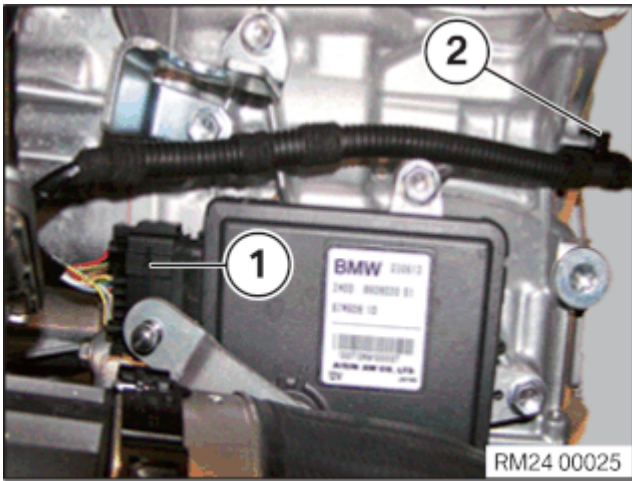

Secure clamp (2) on transmission with the wiring harness.

Lock connector (1).

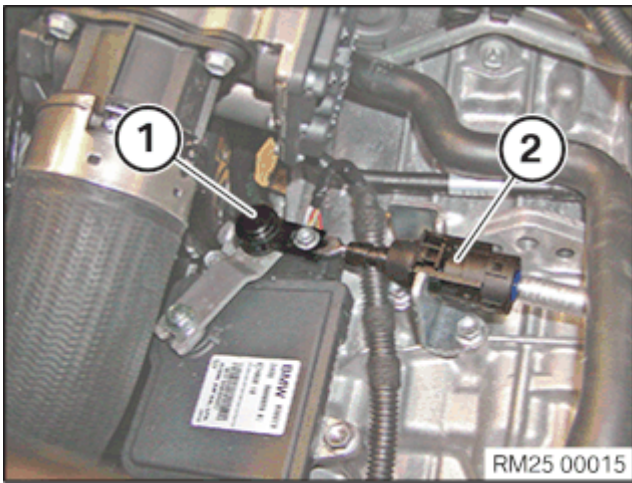

Press the cable (2) into the support angle.

Ensure cable counter support audibly engages.

Press on ball socket (1) onto the ball stud.

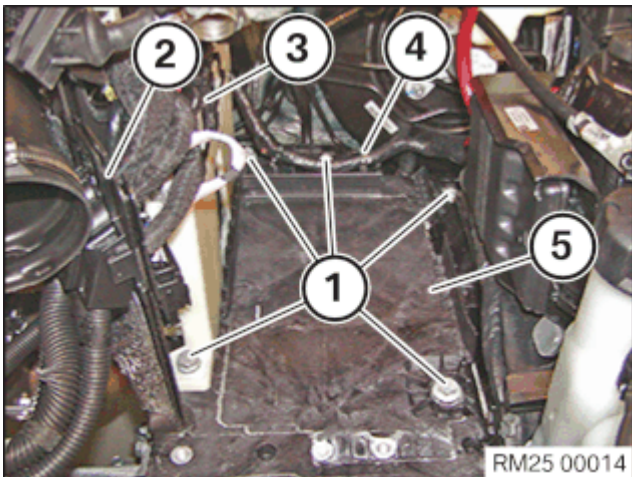

Install battery tray (5).

Tighten down screws (1).

Install wiring harness (4) on the battery tray (5).

Insert control unit (3) into the bracket.

Insert the vehicle battery partition wall (2) into the bracket.



#### Required reworking:

- Install [front axle support](#).
- **No wheel alignment is required for removal and installation of front axle support.**
- Install [left](#) output shaft.
- Install [right](#) output shaft.
- Install [starter](#).
- Install [wheel arch cover](#).
- Install [vehicle battery](#).
- Top up [coolant](#).